

Addendum to Warranty Manual



Espar Heater Systems

Espar Products, Inc.
Tel: (905) 670-0960
(800) 387-4800
Fax: (905) 670-0728
www.espar.com



Table of Contents

Addendum Policy Overview..... 3
Warranty Period..... 3
What IS and IS NOT Covered by the Warranty..... 4
The Espar Flat Rate Labour Guide..... 5

Addendum Policy Overview

This Addendum applies to Specific products developed by Espar. The purpose of this Addendum is to ensure that the end user (customer) of Espar products is satisfied with the quality of their purchase.

Policies and procedures for claim submittal are as outlined in the Warranty Manual.

This Addendum to the Warranty Manual will remain valid until a new addendum is released or until further notice.

Warranty Period

The warranty period of the heater is as specified in the Warranty Manual and other product components (please see “What IS and IS NOT covered under warranty” section) are warranted to be free from defects in material and/or workmanship for 12 (twelve) months from the date of system installation.

What IS and IS NOT Covered by the Warranty

The purpose of the Espar Warranty is to provide the end user (customer) of Espar heaters with protection from defects in material and workmanship.

A. Items covered include:

PARTS

1. Timers, thermostats, mini controllers or other electronic temperature control products provided by Espar
2. Electronic control units (ECU's)
3. Glow pins
4. Fuel metering pumps
5. Heat exchangers and / or combustion chambers (burner)
6. Air blowers
7. Coolant pumps
8. Flame, overheat and temperature sensors
9. O-rings, gaskets, seals
10. Wire Harnesses (only those provided by Espar are warranted; prior authorization is required from Espar's warranty department)

SERVICE

1. Shipping costs associated with the authorized return of warranted parts from the Espar Dealer/Distributor to Espar (only for shipments that contain parts specifically requested by Espar).
2. To receive travel time to repair system installed on boats and/or off-highway heavy equipment, the travel section must be completed on the warranty claim for consideration of payment. Please note that Maximum Limits do apply.

B. Items not covered include but are not limited to:

PARTS

1. Components no longer covered within terms of warranty;
2. Wear and tear parts, including:
 - i. Clamps, clips, brackets
 - ii. Batteries
 - iii. Coolant
 - iv. Atomizer screens
 - v. Fuel system components (i.e. Fuel pickup pipe, fuel line, filters, etc.)
 - vi. Fuses
 - vii. Connectors, terminals and screws
 - viii. Lamp bulbs
 - ix. Intake and exhaust tubing
3. Parts that malfunction due to improper installation, which may result from:
 - i. Inadequate coolant flow;
 - ii. Inadequate or restricted fuel flow;
 - iii. Inadequate voltage due to improper wiring upon installation;
 - iv. Inadequate protection from shock or vibration;
 - v. Inadequate protection from road spray or weather conditions.
4. Components that have been opened, tampered with or modified by parties other than Espar.

5. Using non-standard parts or parts not approved by Espar in the installation.
6. Diagnosis or repairs completed when cause of the problem or failure is due to electrical system problems outside the heater, excessive engine debris or empty fuel tanks or poor quality fuel.
7. Costs incurred through an incorrect diagnosis, poor performance of the repair. This also applies to corrections of installations that did not meet Espar specifications. In these cases the costs incurred are to be charged to original installer.

SERVICE

1. Travel time by dealers/distributors traveling within their assigned territories except as noted in A: **SERVICE** #2 above.
2. Shipping costs associated with the unauthorized return of warranted parts from the Espar Dealer/Distributor to Espar Products.
3. Espar will not pay for return shipping cost to the Dealer/Distributor where parts are deemed acceptable after testing.

Normal periodic heater maintenance (as outlined in each heater manual) shall be the responsibility of the owner of the heater. *A general guideline is to run the heater a minimum of once (1) per month for fifteen (15) minutes all year round.*

The Espar Flat Rate Labour Guide

This flat rate labour guide has been developed from the experience of Espar dealers and distributors.

The flat rate labour guide is organized by system model in order of heat output.

When submitting a warranty claim, it is mandatory to log a detailed description of the repair. The description you have provided should correspond to the fault codes indicated. It is imperative to verify replaced parts as failed parts.

IMPORTANT NOTE:

Espar and Eberspächer have an “Always Repair Heater” policy.

HYBERNATOR

For Hybernator models:

Rail Mount	25 2800 10 0510
In Frame Mount	25 2800 10 0520

Diagram Reference Number	Part Description	Operation	Flat Rate Labour Code	Time Allowance (minutes)	Warranty Authorization Number (WA#) Required
A. Troubleshoot			A	30	
B. Components Replaced with Unit Installed					
1	Hybernator Controller	Replace	HB-B183	15	
2	Coolant Pump	Replace	HB-B200	20	
3	Water Temperature Sensor	Replace	HB-B307	10	
4	AUX Fuel Pump	Replace	HB-B481	20	
5	Fuel-Metering Pump	Replace	H4-B480	15	
6	Hybernator Heat Exchanger	Replace	HB-B011	20	
7	Heater/Temperature Control Device	Replace	HB-B571	15	
8	Hybernator Internal Main Wire Harness	Repair	HB-B581	20	
9	Hybernator Main Wire Harness	Repair	HB-B582	20	
10	Timer/Switch Wire Harness	Repair	HB-B531	20	
8	Hybernator Internal Main Wire Harness	Replace	HB-B515	20	•
9	Hybernator Main Wire Harness	Replace	HB-B526	30	•
10	Timer /Switch Wire Harness	Replace	HB-B532	20	•
C. Components Replaced with Heater Removed			C	60	
11	Electronic Control Unit (Heater ECU in Hybernator)	Replace	HB-C181	10	
12	Blower Unit	Replace	H4-C100	20	
13	Overheat Sensor With Cable	Replace	H4-C240	25	
14	Flame Sensor	Replace	H4-C280	15	
15	Glow Pin	Replace	H4-C310	15	
16	Burner / Flame Tube	Replace	H4-C050	25	
17	O-Rings, Sensors	Replace	H4-C245	15	
18	O-Ring, Heat Exchanger	Replace	H4-C020	30	
19	Seal Kit	Replace	H4-C081	25	
20	Heat Exchanger	Clean	H4-C010	15	•
21	Fuel Connection, Glow pin	Replace	H4-C315	20	•
D. Heater Function Test			D	30	

HYDRONIC 5Z

(No Coolant Pump, External Fuel-Metering Pump)

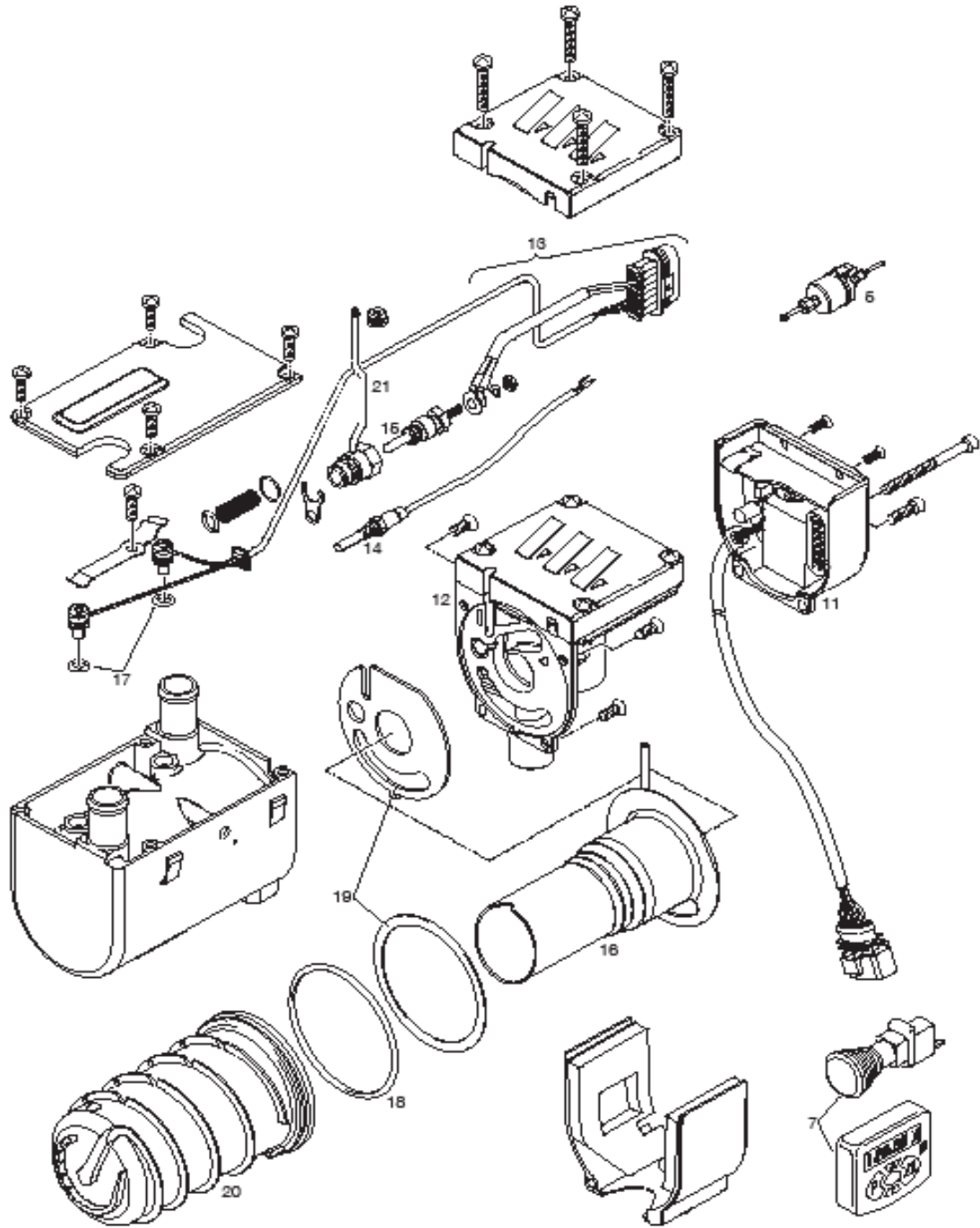

HYBERNATOR

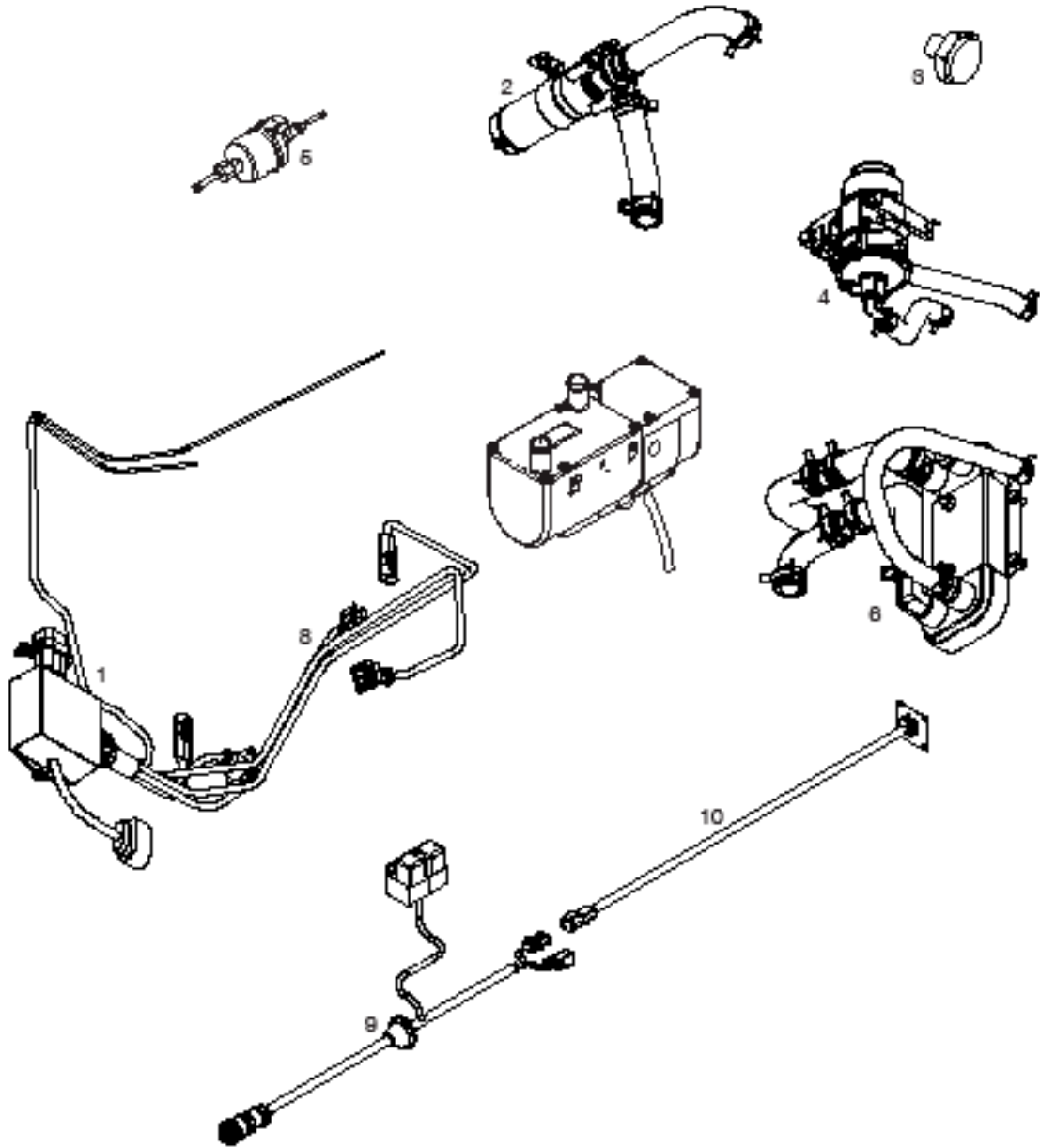

Espar Products, Inc.

(905) 670-0960 Canada

(905) 670-0728 Fax

www.espar.com

A member of the Worldwide **Eberspächer** Group of Companies