

Input: 9V-18V, 40A
Output: 24V, 10A, 288W
 (Use with Hydronic 16 with pump or Hydronic 16, 24, 30, 35 without pump. Coolant pump independantly with relay harness p/n: 25 2800 70 1602.)

Converter heat sink p/n: 20.2900.40.0004

Converter can be mounted on Face B only. 2 heat sinks can be mounted together for more heat dissipation.

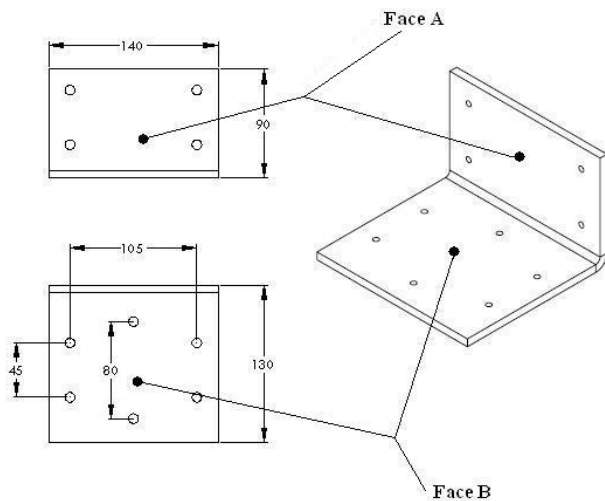

Installation: Converter harness p/n: 25 2800 70 1601
 Fuse p/n: 5670024

1. Find a location close to battery to mount converter. Location must be clean dry and away from hot elements, acid fumes and within length of converter and heater harness. For effective heat removal, the converter must be mounted on a flat metal surface. Optional heat sink shown above. **Do not alter length of wire.**
2. Cut off battery ring terminals from Heater harness.

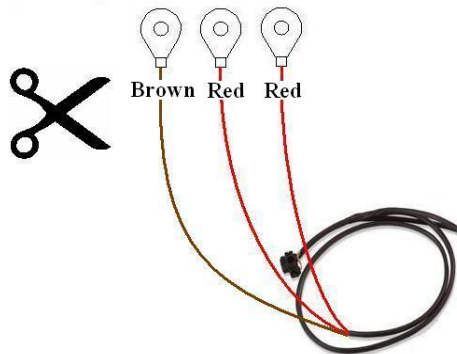

3. Slip included shrink tube over appropriate harness wires, attach included ring terminal to Brown wire in place of battery ring terminal. Attach 2 Red wires to butt joints of "Y" adapter as shown in picture below. Crimping and soldering of terminal and butt joints required, position heat shrink so that it is covering the crimp and solder, apply heat to shrink tube as required.

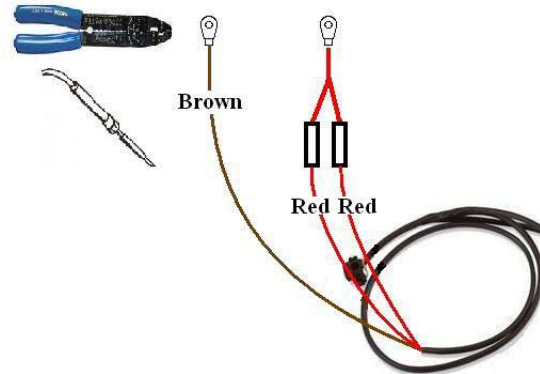

4. Connect wires to harness as shown below.
5. Once terminals are screwed into place brush non-conductive paint on to the terminals to ensure screws are secure.
6. **Secure all wires so they are not hanging loose. Any loose connections may cause a fire.**
7. After all connections are made and the heater is prepared for use, insert 40A fuse. **Remove fuse if heater will not be used for extended period of time.**

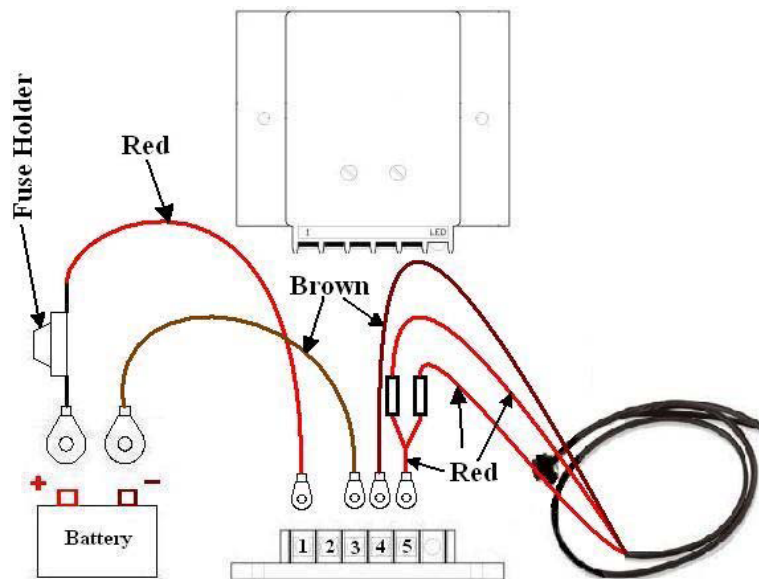

Required Maintenance

- Ensure electrical lines terminals and connectors are always free of corrosion
 - Ensure batterires and all connections are always in good condition