

Assembly p/n: 25.2800.90.1224  
 Converter 12V-24V mod. 3601, p/n: 5673601

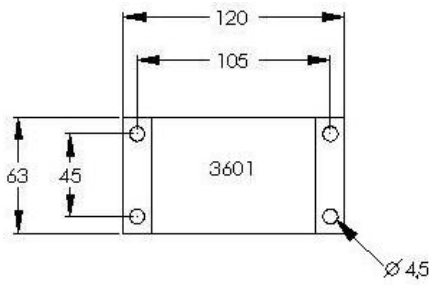

Input: 9V-18V. 40A fuse included into kit.  
 Output: 24V, 17A. 488W max  
 Use with Hydronic 16, 24, 30, 35 with or without coolant pump  
**Converter heat sink p/n: 20.2900.40.0004**  
 Converter can be mounted on Face A or B. 2 heat sinks can be mounted together for more heat dissipation.

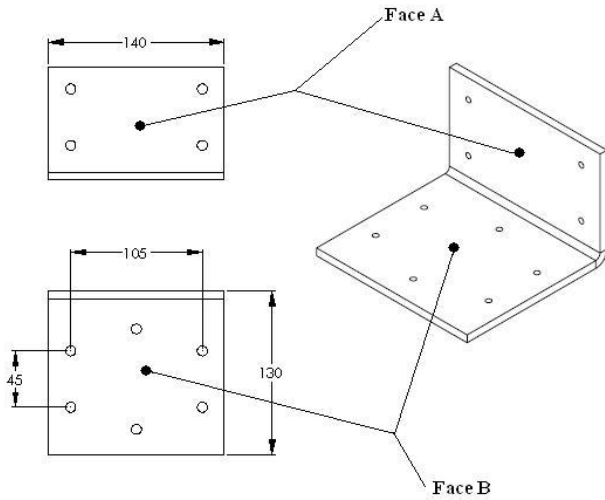

**Installation:** Converter harness p/n: 20.2800.70.1600

1. Find a location close to battery to mount converter. Location must be clean dry and away from hot elements, acid fumes and within length of converter and heater harness. For effective heat removal, the converter must be mounted on a flat metal surface. Optional heat sink shown above. **Do not alter length of wires.**
2. Cut off battery ring terminals from Heater harness.

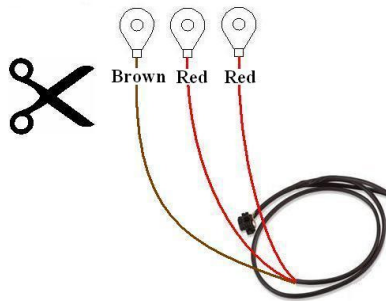

3. Slip included shrink tube on appropriate power wires, attach included ring terminals (4mm stud) to heater harness.
4. Crimping and soldering terminals required. Slide shrink tube so that it covers the crimp and solder and apply heat.

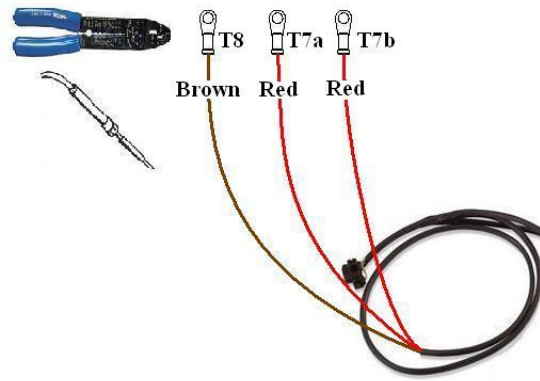

5. Connect **T3** to (+) input terminal of Power Converter.
6. Connect **T4** to (-) input terminal of Power Converter.
7. Connect **T7a** and **T7b** to (+) output terminal of Power Converter.
8. Connect **T8** to (-) output terminal of Power Converter.
9. Connect **T6** to (**RC**) terminal of Power Converter. This connection turns on output circuits of Power Converter.
10. All terminals should be greased to prevent corrosion.
11. **Secure all wires so they are not hanging loose. Any loose connections may cause a fire.**
12. Connect **T2** to (-) battery terminal.
13. Connect **T1** to (+) battery terminal.
14. After all connections are made and the heater prepared for use, insert 40A fuse. **Remove fuse if heater will not be used for extended period of time.**

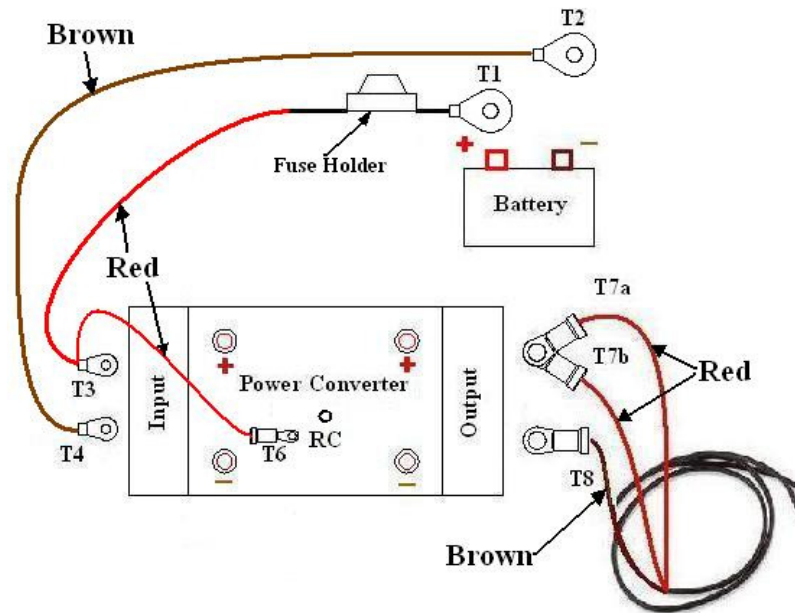

**Required Maintenance:**

- Ensure power converter, electrical wires, terminals and connectors are always clean and free of corrosion.
- Ensure connections are always tightened and in good condition