



Air heater 1 L

Technical description
Installation instructions
Operating instructions
Maintenance instructions

Eberspächer

EN

J. Eberspächer
GmbH & Co. KG
Eberspächerstr. 24
D - 73730 Esslingen

Telephone
(switchboard)
(0711) 939-00
Facsimile
(0711) 939-0500

www.eberspaecher.com

Air heater for petrol and diesel fuel, operating independently of the engine

Heater	Order number	Heater	Order number
B 1 L C <i>compact</i> , 12 V	20 1766 05 00 00	D 1 L C <i>compact</i> , 12 V	25 1976 05 00 00
		D 1 L C <i>compact</i> , 12 V as complete package	25 1979 05 00 00
		D 1 L C <i>compact</i> , 24 V	25 1977 05 00 00
		D 1 L C <i>compact</i> , 24 V as complete package	25 1978 05 00 00



**Please give this manual to the customer
after installation of the heater.**

1 Introduction

Contents

Chapter	Title	Contents	Page
1	Introduction	<ul style="list-style-type: none">• Contents 2• Concept of this manual 3• Special text structure, presentation and picture symbols 4• Important information before starting work 4• Statutory regulations 5, 6• Safety instructions for installation and operation 6, 7• Accident prevention 7	
2	Product information	<ul style="list-style-type: none">• Scope of supply 9• Technical data for the B 1 L C <i>compact</i> 10• Technical data for the D 1 L C <i>compact</i> 11• Main dimensions 12	
3	Installation	<ul style="list-style-type: none">• Installation and location 13• Installing the 24 V heater in a vehicle for the transport of dangerous goods 13• Installation location 14• Possible installation positions 15• Mounting and fastening 16• Nameplate 17• Heater air system 18• Exhaust system 19• Combustion air system 20• Fuel supply 21 – 25	
4	Operation and function	<ul style="list-style-type: none">• Operation instructions / important information for operation 26• Initial commissioning 26• Description of functions 27• Control an safety devices / EMERGENCY OFF 28	
5	Electrical system	<ul style="list-style-type: none">• Heater wiring 29• Parts list for the circuit diagrams 29, 30• Circuit diagrams at the end of this manual	
6	Faults Maintenance Service	<ul style="list-style-type: none">• Which items to check if faults occur 31• Troubleshooting 31• Maintenance instructions 31• Service 31	
7	Environment	<ul style="list-style-type: none">• Certification 32• Disposal 32• EU Declaration of Conformity 32	
8	Lists	<ul style="list-style-type: none">• List of key words 33, 34• List of abbreviations 34	



1 Introduction

Concept of this manual

This manual aims to support the service company installing the heater and to provide the user with all important information about the heater. The manual has been divided into 8 chapters to make it easier to find the corresponding information quickly.

1 Introduction

Here you find important introductory information about installation of the heater and about the structure of the manual.

2 Product information

Here you will find information about the scope of supply, the technical data and the dimensions of the heater.

3 Installation

Here you will find important information and instructions referring to installation of the heater.

4 Operation and function

Here you will find information about the operation and function of the heater.

5 Electrical system

Here you will find information about the electronic system and electronic components of the heater.

6 Troubleshooting / maintenance / service

Here you will find information about possible faults, troubleshooting, servicing / maintenance and the service hotline.

7 Environment

Here you will find information about certification and disposal of the heater together with the EU Declaration of Conformity.

8 Lists

Here you will find the key word list and abbreviations list.

1 Introduction

Special text structure, presentation and picture symbols

This manual uses special text structures and picture symbols to emphasize different contents.

Please refer to the examples below for the corresponding meanings and associated actions.

Special structure and presentations

A dot (•) indicates a list which is started by a heading.

If an indented dash (-) follows a dot, this list is subordinate to the dot.

Picture symbols



Regulation!

This picture symbol with the remark „Regulation“ refers to a statutory regulation.

Failure to comply with this regulation results in expiry of the type permit for the heater and preclusion of any guarantee and liability claims on J. Eberspächer GmbH & Co. KG and its associated companies.



Danger!

This picture symbol with the remark „Danger“ refers to the risk of fatal danger to life and limb.

Under certain circumstances, failure to comply with these instructions can result in severe or life-threatening injuries.



Caution!

This picture symbol with the remark „Caution“ refers to a dangerous situation for a person and / or the product.

Failure to comply with these instructions can result in injuries to people and/or damage to machinery.

Please note!

These remarks contain application recommendations and useful tips for installation of the heater.

Important information before starting work

Range of application of the heater

The air heater operating independently of an engine is intended for installation in the following vehicles:

- All types of motor vehicles and their trailers
- Construction machinery
- Agricultural machinery
- Boats, ships and yachts (only diesel heaters)
- Camper vans

Please note!

- The heater is approved for installation inside vehicle spaces used by people (max. 9 seats), subject to compliance with the statutory requirements and notes given in the contents of these instructions.
- The D 1 L C *compact* – 24 Volt heater can be installed in vehicles used for the transport of hazardous goods according to ADR / ADR99.

Purpose of the heater

- Pre-heating, de-misting windows
- Heating and keeping the following warm:
 - Driver and working cabs, ship's cabins
 - Freight compartments
 - Passenger and crew compartments
 - Camper vans

On account of its functional purpose, the heater is not approved for the following applications:

- Long-term continuous operation, e.g. for preheating and heating of:
 - Residential rooms, garages
 - Work huts, weekend homes and hunting huts
 - House boat, etc.
- Heating or drying of:
 - Living creatures (people or animals) by blowing hot air directly at the subject
 - Objects
 - Blowing hot air into containers



Caution!

Safety instructions for application and proper purpose!

- The heater must only be used and operated for the range of application stated by the manufacturer in compliance with the „Operation instructions“ included with every heater.



1 Introduction

Statutory regulations

The Federal Road Transport Directorate has issued an "EC type approval" and an "EMC type approval" for the heater for installation in motor vehicles and with the following official type approval marks, noted on the heater name plate.

Air heater 1L EC-e100 0055

EMC-e1021063



Regulation!

• Arrangement of the heater

- Parts of the structure and other components near the heater must be protected from excess heat exposure and possible contamination from fuel or oil.
- The heater must not pose a fire hazard even when it overheats. This requirement is deemed to be fulfilled when adequate clearance to all parts is observed during installation, sufficient ventilation is provided and fire-proof materials or heat plates are used.
- The heater must not be mounted in the passenger compartment of vehicles in class M₂ and M₃. But a heater in a hermetically sealed enclosure which otherwise complies with the conditions stated above may be used.
- The factory nameplate or duplicate must be affixed so that it can still be easily read when the heater is installed in the vehicle.
- All appropriate precautions must be taken when arranging the heater to minimise the risk of injuries to persons or damage to other property.

• Operating status display

- A clearly visible operating display in the user's field of vision must indicate when the heater is switched on an off.

• Fuel supply

- The fuel intake connection must not be located in the passenger compartment and must be sealed with a properly closing lid to prevent any fuel leaks.
- In heaters for liquid fuel where the heater fuel is separate from the vehicle fuel, the type of fuel and intake connection must be clearly identified.
- A warning sign is to be fixed to the intake connection indicating that the heater must be switched off before refuelling.

• Exhaust system

- The exhaust outlet must be arranged so as to prevent any penetration of exhaust fumes into the vehicle interior through the ventilation system, warm air intakes or open windows.

• Combustion air intake

- The air for the heater combustion chamber must not be sucked in from the passenger compartment of the vehicle.
- The air intake must be arranged or protected in such a way that it cannot be blocked by other objects.

• Heater air intake

- The heater air supply must consist of fresh air or circulated air and be sucked in from a clean area not contaminated by exhaust fumes of the drive machine, the combustion heater or any other source in the vehicle.
- The intake pipe must be protected by a grid or other suitable means.

• Hot air outlet

- The hot air pipes within the vehicle must be arranged or protected in such a way that there is no risk of injury or damage if they are touched.
- The air outlet must be arranged or protected in such a way that it cannot be blocked by any objects.

1 Introduction

Statutory regulations



Regulation!

Mounting the heater in a vehicle for the transport of dangerous goods as per ADR / ADR99

- When the heater is to be installed in vehicles for the transport of dangerous goods, the regulations of ADR / ADR99 must be observed.

Please note!

- Compliance with the statutory regulations and safety instructions is prerequisite for guarantee and liability claims. Failure to comply with the statutory regulations and safety instructions and incorrect repairs even when using original spare parts make the guarantee null and void and preclude any liability for J. Eberspächer GmbH & Co. KG.
- Detailed information about the regulations of ADR / ADR99 are contained in the information leaflet no. 25 2161 95 15 80 (see also page 13 and 28).
- Subsequent installation of this heater must comply with these installation instructions.
- The statutory regulations are binding and must also be observed in countries which do not have any special regulations.
- When the heater is to be installed in vehicles not subject to the German Ordinance for the Registration of Motor Vehicles (StVZO), for example ships, the specially valid regulations and installation instructions for these special applications must be observed.
- Installation of the heater in special vehicles must comply with the regulations applying to such vehicles (for example for vehicles for the transport of dangerous goods as per ADR / ADR99).
- Other installation requirements are contained in the corresponding sections of this manual.

Safety instructions for installation and operation



Danger!

Risk of injury, fire and poisoning!

- The heater must only be started up when the maintenance flap is closed and the outlet hood is mounted in position.
- The maintenance flap must not be opened during operation.
- Disconnect the vehicle battery before commencing any kind of work.
- Before working on the heater, switch the heater off and let all hot parts cool down.
- The heater must not be operated in closed rooms, e.g. in the garage or in a multi-story car park.
- Adjustable hot air outlets must always be adjusted so that they cannot blow hot air directly at living creatures (people, animals) or object sensitive to temperature (loose and / or fastened).



Caution!

Safety instructions for installation and operation!

- The year of initial commissioning must be marked on the nameplate.
- The heat exchanger of air heaters is a component subject to high thermal loads which must be replaced 10 years after initial commissioning of the heater. In addition, the installation date must be entered on the plate „original spare part“ enclosed with the heat exchanger. Then affix the plate next to the nameplate on the heater.
- The heater must only be installed by a JE partner authorised by the manufacturer according to the instructions in this manual and possibly according to special installation recommendations; the same applies to any repairs to be carried out in the case of repairs or guarantee claims.
- Only the control elements approved by J. Eberspächer GmbH & Co. KG may be used to operate the heater. Use of other control elements can cause malfunctions.



1 Introduction

Safety instructions for installation and operation



Caution!

Safety instructions for installation and operation!

- Repairs by unauthorised third parties and / or not using original spare parts are dangerous and therefore not allowed. They result in expiry of the type permit of the heater; consequently, when installed in motor vehicles they can cause expiry of the vehicle operating licence.
- The following measures are not allowed:
 - Changes to components relevant to the heater.
 - Use of third-party components not approved by Eberspächer.
 - Nonconformities in installation or operation from the statutory regulations, safety instructions or specifications relevant to safe operation as stated in the installation instructions and operating instructions. This applies in particular to the electrical wiring, fuel supply, combustion air system and exhaust system.
- Only original accessories and original spare parts must be used during installation or repairs.
- When carrying out electric welding on the vehicle, the plus pole cable at the battery should be disconnected and placed at ground to protect the controller.
- The heater must not be operated where there is a risk of an accumulation of flammable vapours or dust, for example close to
 - fuel depot
 - coal depot
 - wood depot
 - grain depots etc.
- The heater must be switched off when refuelling.
- When the heater is mounted in a safety housing etc., the installation compartment of the heater is not a stowage compartment and must be kept clear. In particular fuel canisters, oil cans, spray cans, gas cartridges, fire extinguishers, cleaning rags, items of clothing, paper etc. must not be stored or transported on or next to the heater.
- Defect fuses must only be replaced by fuses with the prescribed rating.
- If fuel leaks from the heater fuel system, arrange for the damage to be repaired immediately by a JE service partner.
- After-running of the heater must not be interrupted prematurely e.g. by pressing the battery disconnecting switch, apart from in the case of an emergency stop.

Accident prevention

General accident prevention regulations and the corresponding workshop and operation safety instructions are to be observed.

2 Product information

Scope of supply

Quantity / Designation	Order number
------------------------	--------------

1 B 1 L C <i>compact</i> – 12 V	20 1766 05 00 00
---------------------------------	------------------

To be ordered separately:

1 Universal installation kit	25 1976 80 00 00
------------------------------	------------------

1 Control element*	–
--------------------	---

or

1 D 1 L C <i>compact</i> – 12 V	25 1976 05 00 00
---------------------------------	------------------

To be ordered separately:

1 Universal installation kit	25 1976 80 00 00
------------------------------	------------------

1 Control element*	–
--------------------	---

or

1 D 1 L C <i>compact</i> – 12 V as complete package**	25 1979 05 00 00 –
--	-----------------------

To be ordered separately:

1 Control element*	–
--------------------	---

or

1 D 1 L C <i>compact</i> – 24 V	25 1977 05 00 00
---------------------------------	------------------

To be ordered separately:

1 Universal installation kit	25 1976 80 00 00
------------------------------	------------------

1 Control element*	–
--------------------	---

or

1 D 1 L C <i>compact</i> – 24 V as complete package**	25 1978 05 00 00
--	------------------

To be ordered separately:

1 Control element*	–
--------------------	---

* Control units see price list / accessories catalogue.

The control device or module clock is absolutely necessary for operation of the heater.

** Complete package contains:

1 Heater

1 Universal installation kit

Parts list for the picture „Scope of supply“ on page 9

Scope of supply for heater

Pict. No.	Designation
-----------	-------------

1	Heater
2	Dosing pump
3	Cap

Scope of supply for universal installation kit

Pict. No.	Designation
-----------	-------------

4	Cable tree, heater
5	Cable harness, plus / minus
6	Cable harness, controls
7	Flexible exhaust pipe
8	Combustion air hose
9	Cable tie
10	Bracket, dosing pump
11	Pipe, 6 x 2
12	Pipe, 4 x 1
13	Hose, 5 x 3
14	Outlets, rotating
15	Grid
16	Hood
17	Flexible pipe
18	Hose clip

Please note!

- Parts without picture number are small parts and packed in a bag.
- Please consult the additional parts catalogue if any other parts are required for installation.



2 Product information

Heater and installation kit scope of supply

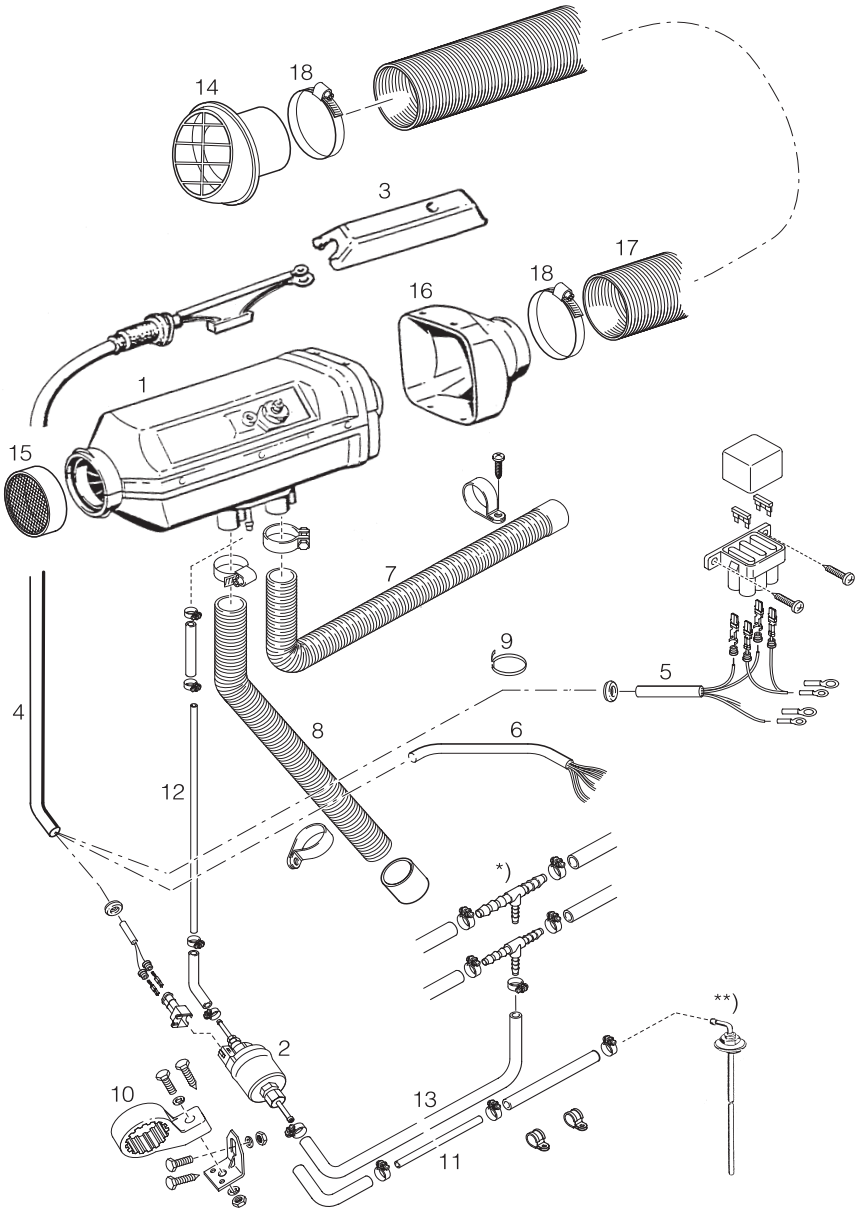

*) The installation kit 25 1978 05 00 00 does not contain the T-pieces.

***) The installation kit 25 1979 05 00 00 does not contain the tank remover.

2 Product information

Technical data

Heater		B 1 L C compact			
Heating medium		Air			
Control of the heat flow		Stage			
		Power	Large	Medium	Small
Heat flow (watt)		2200	1800	1200	850
Heater air flow rate without counterpressure		110 kg/h	95 kg/h	65 kg/h	50 kg/h
Heater code		6 for outlet hood Ø 60 mm			
		15 for outlet hood Ø 75 mm			
Fuel consumption (l/h)		0.3	0.24	0.16	0.12
Electr. power (watt)		in operation			
		30	22	10	8
		while starting			
		250			
		in the control phase „off“			
		8			
Rated voltage		12 Volt			
Operating range					
Lower voltage limit: An undervoltage protection in the controller switches the heater off on reaching the voltage limit.		10.5 Volt			
Upper voltage limit: An overvoltage protection in the controller switches the heater off on reaching the voltage limit.		16 Volt			
Fuel „Fuel quality“ and „fuel at low temperatures“ see operating instructions page 25.		Commercially available petrol (DIN EN 228)			
Tolerable operating temperature					
Heater		Operation			
		-40 °C to +50 °C			
		Storage			
		-40 °C to +85 °C			
Dosing pump		Operation			
		-40 °C to +70 °C			
		Storage			
		-40 °C to +85 °C			
Interference suppression		Far (further measures possible)			
Weight		ca. 3.5 kg			



Caution!

Safety instructions for technical data!

Failure to comply with the technical data can result in malfunctions.

All technical data ±10 %



2 Product information

Technical data

Heater		D 1 L C compact				
Heating medium		Air				
Control of the heat flow		Stage				
		Power	Large	Medium	Small	
Heat flow (watt)		2200	1800	1200	850	
Heater air flow rate without counterpressure		110 kg/h	95 kg/h	65 kg/h	50 kg/h	
Heater code		6 for outlet hood Ø 60 mm				
		15 for outlet hood Ø 75 mm				
Fuel consumption (l/h)		0.27	0.21	0.14	0.10	
Electr. power (watt)		in operation	30	22	10	8
		while starting	250 (for 12 Volt) and 210 (for 24 Volt)			
		in the control phase „off“	8			
Rated voltage		12 Volt		24 Volt		
Operating range Lower voltage limit: An undervoltage protection in the controller switches the heater off on reaching the voltage limit.		10.5 Volt		21 Volt		
		Upper voltage limit: An overvoltage protection in the controller switches the heater off on reaching the voltage limit.		16 Volt		32 Volt
Fuel „Fuel quality“ and „fuel at low temperatures“ see operating instructions page 25.		Commercially available diesel (DIN EN 590) Bio diesel PME (DIN V 51606)				
Tolerable operating temperature						
Heater		Operation	-40 °C to +70 °C			
		Storage	-40 °C to +85 °C			
Dosing pump		Operation	-40 °C to +50 °C			
		Storage	-40 °C to +85 °C			
Interference suppression		Far (further measures possible)				
Weight		ca. 3.5 kg				



Caution!

Safety instructions for technical data!

Failure to comply with the technical data can result in malfunctions.

All technical data ±10 %



3 Installation

Installation and location

The heater is suitable and certified for installation in parts of vehicles used by persons. Installation in the cab or passenger compartments of coaches or buses with more than 9 seats is **not** allowed.

When installing in compartments used by persons, the exhaust, combustion air and fuel pipes in these areas must not have any detachable connections and must be routed splash-waterproof in the breakthroughs. For this reason, the heater can be mounted with its foot using the flange seal in the foot to the vehicle floor or to an outer wall of the vehicle.

The electronic control is integrated in the heater which makes wiring during installation much easier.

Please note!

- When installing the heater, always make sure there is sufficient clearance left for intake of the heater air and for dismantling the glow plug and controller.
- Observe the regulations and safety instructions for this chapter, given on page 4 – 7.

Installing the 24 V heater in a vehicle for the transport of dangerous goods as per ADR / ADR99

Heaters (24 volt) are allowed to be installed in vehicles used for the transport of dangerous goods as per ADR / ADR99.

The heater fulfils the regulations of ADR / ADR99 with the corresponding electrical wiring, see circuit diagrams at the end of this manual.

Detailed information about the regulations of ADR / ADR99 is contained in the leaflet no. 25 2161 95 15 80.

Please note!

When the heater is to be installed in vehicles for the transport of dangerous goods, the regulations of ADR / ADR99 must be observed.

3 Installation

Installation location

Installation in a car or people carrier

In a car or people carrier, the heater is preferably installed in the passenger compartment or boot. If it is not possible to install the heater in the passenger compartment or boot, the heater can also be mounted under the vehicle floor.

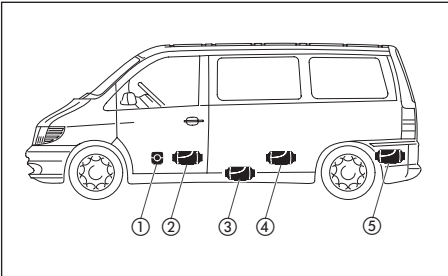

- ① Heater in front of the passenger seat
- ② Heater between the driver's seat and the passenger seat
- ③ Heater under the vehicle floor
- ④ Heater under the back seat
- ⑤ Heater in the boot

Installation in an excavator cab

In an excavator, the heater is preferably installed in the cab. If it is not possible to install the heater in the cab, the heater can also be installed in a storage box outside the cab.

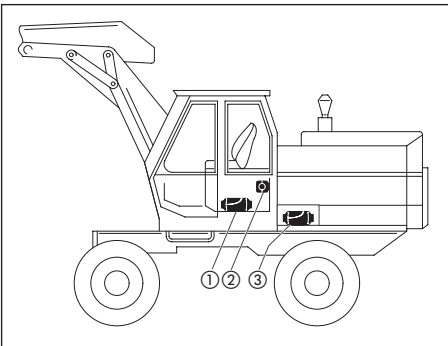

- ① Heater in the seat box
- ② Heater on the cab rear wall
- ③ Heater in the safety housing

Installation in a truck

In a truck, the heater is preferably installed inside the driver's cab.

If it is not possible to install the heater inside the driver's cab, it can also be mounted in the tool box or in a storage box.

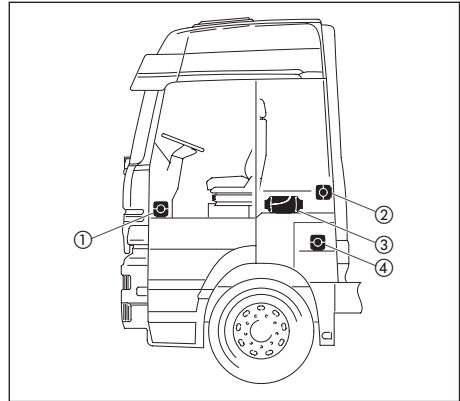

- ① Heater in the passenger's foot room
- ② Heater on the cab rear wall
- ③ Heater under the bed
- ④ Heater in the tool box

Please note!

- The installation suggestions made in the installation instructions are just examples. Other installation locations are possible, as long as they correspond to the installation requirements stated in these instructions.
- Other installation information (e.g. for boats and ships) is available from the manufacturer on request.
- Observe the tolerable installation position together with the operating and storage temperatures.



3 Installation

Possible installation positions

The heater is preferably installed in the normal position as shown in the drawing. Depending on the installation conditions, the heater can be tilted by max. 30° (flow direction to the bottom) or turned by max. 90° around its own longitudinal axis (exhaust connection horizontal, glow plug points upwards!).

In the heating mode, the heater can deviate from the shown normal or maximum installation positions by up to +15° in all directions because of a slanting position of the vehicle or boat, without any impaired functions.

Normal position horizontal (exhaust connection downwards) with tolerable swivel range

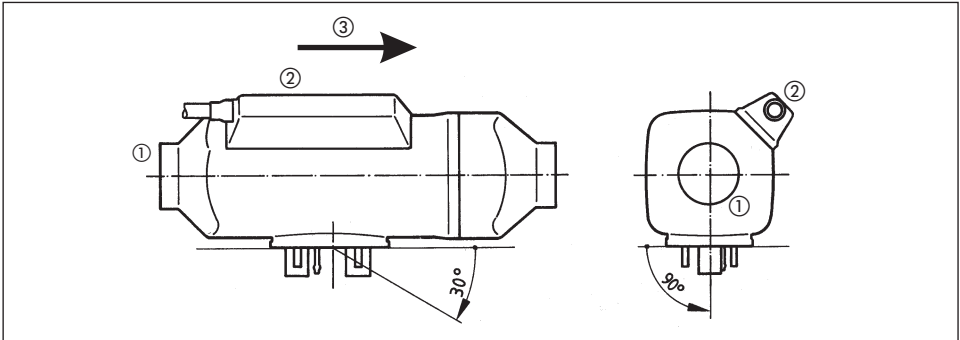

- ① Heater air intake opening (fan wheel)
- ② Position of the glow plug
- ③ Direction of flow

3 Installation

Mounting and fastening

Make the necessary breakthroughs for exhaust, combustion air and fuel as shown in the hole diagram. The support surface for the heater foot must be flat. An appropriate tool can be purchased from the manufacturer for drilling the breakthroughs and also smoothing the support surface. The hole \varnothing 10.5 mm for the cable harness „dosing pump“ is not included in the picture drawing and must be drilled after installation.

If the sheet metal of the support surface is thinner than 1.5 mm, an additional reinforcement plate will have to be fitted.

Order no: reinforcement plate 20 1577 89 00 03

Order no: special tool 99 1201 46 53 29

Picture hole

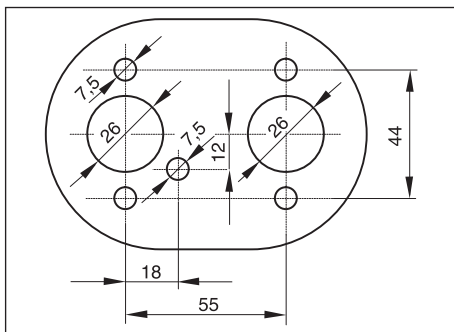

Special tool

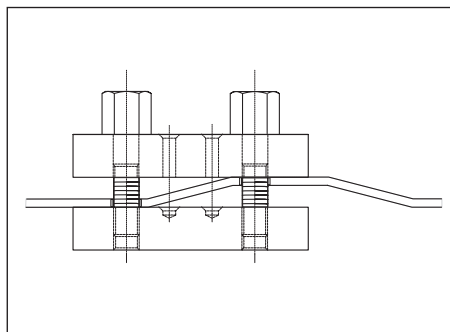

Fastening the unit on the vehicle floor

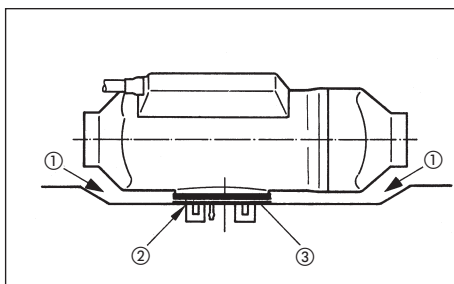

Fastening the heater horizontally to the vehicle wall

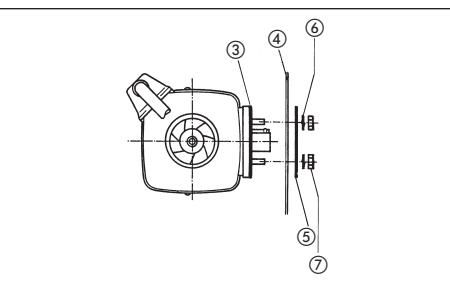

- ① There must be sufficient clearance between the heater and the vehicle floor – also check that the fan wheel runs freely.
- ② The mounting surface must be flat and smooth.
- ③ The flange seal must be mounted.

- ④ The vehicle wall must be flat and smooth.
- ⑤ Reinforcement plate (if required, see above)
- ⑥ Spring washer
- ⑦ Hexagon nut M6 (torque 5^{+1} Nm)



3 Installation

Nameplate

The nameplate is fixed on the upper jacket shell. The 2nd nameplate (duplicate) is included in the heater's scope of supply and, if necessary, can be stuck onto an easily visible place on the heater or in the area of the heater.

Please note!

The regulations and safety instructions to be observed for this chapter are stated on page 5.

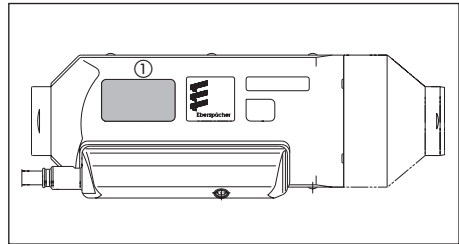

① Original nameplate

3 Installation

Heater air system

The universal installation kit includes a flexible pipe, an outflow and a safety grid for the heater air system.



Danger!

Risk of burning and injuries!

- The hoses of the heater air system and the hot air outlet are to be routed and fastened in such a way that they pose no temperature risk to people, animals or materials sensitive to temperature from radiation / contact or blowing directly. If necessary, a cover is to be fitted to the heater air system or hot air outlet.
- The outflow hood must be fitted on the hot air outflow side.
- A safety grid must be fitted to the heater air intake side and outflow side if no air hoses are mounted, to prevent any injuries from the heater air fan or burns from the heat exchanger.
- High temperatures occur in the heater air system during and after the heater has been working. This is why it is important to avoid working in the vicinity of the heater air system while the heater is working. In such cases, switch the heater off beforehand and wait until all parts have cooled down completely. If necessary, wear safety gloves.

Please note!

- Comply with the regulations and safety instructions for this chapter given on page 4 - 7.
- Note the equipment code in the technical data (page 10 and 11) when connecting up air conveying parts.



Caution!

- The heater air intake openings must be arranged in such a way that under normal circumstances, it is not possible for exhaust from the vehicle engine and heater to be sucked into the system, or for the heating air to be contaminated with dust, salt spray, etc.
- For circulating air, position the circulating air intake in such a way that the outflowing hot air cannot be directly sucked in again.
- In the event of possible overheating, it is possible for local hot air temperatures of up to max. 150 °C or surface temperatures of up to max. 80 °C to occur immediately before the defect shutdown. Therefore only temperature-resistant hot air hoses approved by us must be used for the heater air system!
- When checking the functions, the mean outflow temperature measured after the heater has been running about 10 minutes at approx. 30 cm from the outlet should not exceed 110 °C (at an intake temperature of approx. 20 °C).
- If there is a risk of the driver and passengers touching the heater when the vehicle is being driven normally, a contact protection device must be fitted.

Heater air system (example)

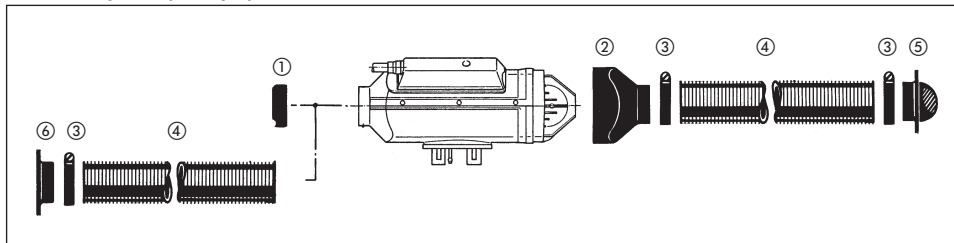

① Safety grid

② Outflow hood

③ Hose clip

④ Flexible hose

⑤ Rotating outflow

⑥ Connection fitting with safety grid



3 Installation

Exhaust system

Mounting the exhaust system

The universal installation kit includes a flexible exhaust pipe, inner \varnothing 24 mm, 1000 mm long and an exhaust silencer.

The flexible exhaust pipe can be shortened to 20 cm or lengthened to max. 2 m, depending on the installation conditions.

Fasten the exhaust silencer to a suitable position in the vehicle.

Route the flexible exhaust pipe from the heater to the exhaust silencer and fasten with pipe clips.

Connect an exhaust end pipe to the exhaust silencer with a pipe clip.

After finishing all installation work, place an end sleeve on the exhaust end pipe.

(Exhaust diagram see page 20).



Caution!

Safety instructions!

The whole exhaust system gets very hot during and immediately after the heater has been working.

This is why the exhaust system must be routed according to these installation instructions

- The exhaust pipe must end in the open air.
- The exhaust pipe must not protrude beyond the lateral limits of the vehicle.
- Install the exhaust pipe sloping slightly downwards. If necessary, make a drain hole approx. \varnothing 5 mm at the lowest point to drain off condensation.
- Important functional parts of the vehicle must not be impaired (keep sufficient clearance).
- Mount the exhaust pipe with sufficient clearance to heat-sensitive parts. Pay particular attention to fuel pipes (plastic or metal), electrical cables and brake hoses etc.!
- Exhaust pipes must be fastened safely (recommended clearance of 50 cm) to avoid damage from vibrations.
- Route the exhaust system so that the emitted fumes are not sucked in with the combustion air.
- The mouth of the exhaust pipe must not be clogged by dirt and snow.
- The mouth of the exhaust pipe must not point in the direction of travel.
- Always fasten the exhaust silencer to the vehicle.



Danger!

Risk of injuries and burns!

Every type of combustion produces high temperatures and toxic exhaust fumes.

This is why the exhaust system must be routed according to these installation instructions

- Do not perform any work on the exhaust system while the heater is working.
- Before working on the exhaust system, first switch the heater off and wait until all parts have cooled down completely, wear safety gloves if necessary.
- Do not inhale exhaust fumes.

Please note!

- Comply with the regulations and safety instructions for this chapter given on page 4 – 7.

3 Installation

Combustion air system

Mounting the combustion air system

The universal installation kit includes a flexible combustion air hose, inner $\text{\O} 25 \text{ mm}$, 1000 mm long. If necessary the flexible combustion air hose can be shortened to 20 cm or lengthened to max. 2 m depending on the installation conditions.

Fasten the combustion air hose to the heater with a pipe clip and at suitable points with hose clips or cable ties.

After completing all the installation work, place an end sleeve on the combustion air hose.

In addition, a combustion air intake silencer can be inserted in the combustion air circuit to dampen the noise (See additional parts catalogue for order no.).

Please note!

Comply with the regulations and safety instructions for this chapter given on page 4 – 7.



Caution!

Safety instructions for the combustion air system!

- The combustion air opening must be free at all times.
- Position the combustion air intake to be sure that exhaust fumes cannot be sucked in with the combustion air.
- Do not arrange the combustion air intake to pointing against the wind blast.
- The combustion air intake must not get clogged with dirt and snow.
- Install the combustion air intake system sloping slightly downwards. If necessary, make a drain hole approx. $\text{\O} 5 \text{ mm}$ at the lowest point to drain off condensation.

Exhaust and combustion air circuit

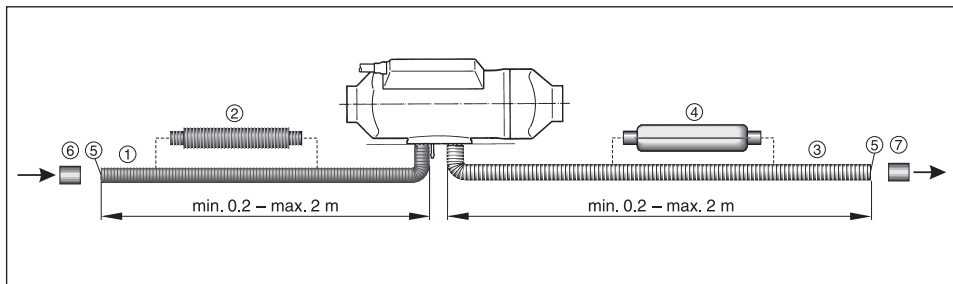

- ① Combustion air hose, $d_i = 25 \text{ mm}$
- ② Combustion air silencer, optional
- ③ Flexible exhaust pipe, $d_i = 24 \text{ mm}$
- ④ Exhaust silencer, optional
- ⑤ Intake / outlet opening – protect from wind, snow, dirt and water
- ⑥ End sleeve for the combustion air hose
- ⑦ End sleeve for flexible exhaust pipe



3 Installation

Fuel supply

Mounting the dosing pump, routing the fuel pipes and mounting the fuel tank

The following safety instructions must be observed when mounting the dosing pump, routing the fuel pipes and mounting the fuel tank. Deviations from the instructions stated here are not allowed. Failure to comply can result in malfunctions.



Danger! Risk of fire, explosion, poisoning and injuries!

Caution when handling fuel.

- Switch off the vehicle engine and heater before refuelling and before working on the fuel supply.
- No naked lights when handling fuel.
- Do not smoke.
- Do not inhale petrol fumes.
- Avoid any contact with the skin.



Caution! Safety instructions for routing the fuel pipes!

- Only use a sharp knife to cut off fuel hoses and pipes. Interfaces must not be crushed and must be free of burrs.
- The fuel pipe from the dosing pump to the heater should be routed at a continuous rise.
- Fuel pipes must be fastened safely to avoid any damage and / or noise production from vibrations (recommended clearance of approx. 50 cm).
- Fuel pipes must be protected from any mechanical damage.

- Route the fuel pipes so that any distortion of the vehicle, engine movements etc. cannot have any lasting effect on the service life.
- Parts carrying fuel must be protected from interfering heat.
- Never route or fasten the fuel pipes to the heater or vehicle exhaust system. When the systems cross, always ensure there is a sufficient heat clearance. If necessary, install heat deflection plates.
- Dripping or evaporating fuel must never be allowed to collect on hot parts or ignite on electric systems.
- When connecting fuel pipes with a fuel hose, always mount the fuel pipes in a butt joint to prevent any bubbles from forming.

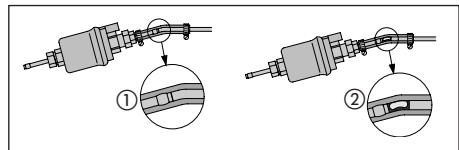

- ① Correct connection
② Pipe laid incorrectly – bubbles form

Safety instructions for fuel pipes and fuel tanks in buses and coaches

- In buses and coaches, fuel pipes and fuel tanks must not be routed through the passenger compartment or driver's cab.
- Fuel tanks in buses and coaches must be positioned in such a way that the exits are not in direct danger from a possible fire.

Please note!

Comply with the regulations and safety instructions for this chapter given on page 4 – 7.

3 Installation

Fuel supply

Fuel feed point with T-piece from the fuel supply line from the tank fitting to the vehicle engine

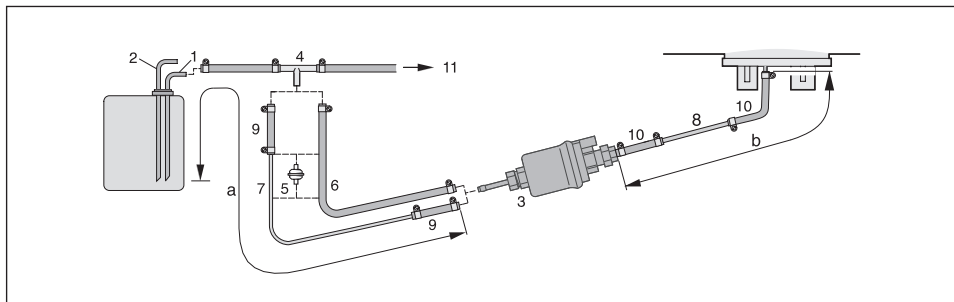

- ① Fuel feed pipe from tank connection
- ② Fuel return pipe to the tank connection
- ③ Dosing pump
- ④ T-piece, 8-6-8
- ⑤ Fuel filter – only necessary for contaminated fuel.
- ⑥ Fuel hose, 5 x 3 (di = Ø 5 mm)
- ⑦ Fuel pipe, 6 x 2 (di = Ø 2 mm)
- ⑧ Fuel pipe, 4 x 1.25 (di = Ø 1.5 mm)
- ⑨ Fuel hose, 5 x 3 (di = Ø 5 mm), ca. 50 mm long
- ⑩ Fuel hose, 3.5 x 3 (di = Ø 3.5 mm), ca. 50 mm long
- ⑪ To the engine, mechanical fuel or injection pump.

Permissible pipe lengths for petrol heater

Intake side	Pressure side
a = max. 2 m	b = max. 4 m

Permissible pipe lengths for diesel heater

Intake side	Pressure side
a = max. 5 m	<ul style="list-style-type: none"> • For suction pipe, di = Ø 2 mm b = max. 6 m • For suction pipe, di = Ø 5 mm b = max. 10 m

Please note!

Insert the T-piece ④ before the feed pump in the fuel feed pipe.

Item ⑤ is not included in the „installation set“, see additional parts catalogue for the order no.

Installation position of the T-piece

Use the installation positions shown in the diagram when inserting a T-piece.

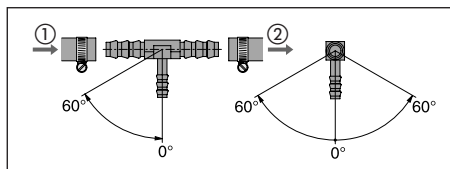

- ① Direction of flow from the fuel tank
- ② Direction of flow to the vehicle engine



3 Installation

Fuel supply

Fuel feed point with tank connection – ascending pipe, integrated in the vehicle tank or in the tank fitting

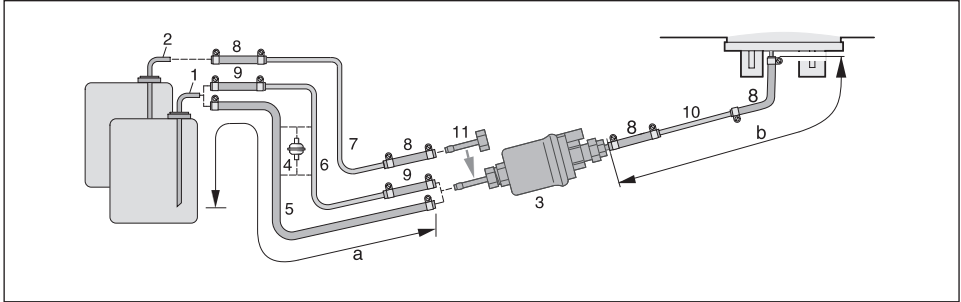

- ① Tank connection for metal tank
– di = Ø 2 mm, da = Ø 6 mm
- ② Tank connection for tank fitting
– di = Ø 2 mm, da = Ø 4 mm
- ③ Dosing pump
- ④ Fuel filter – only required for contaminated fuel.
- ⑤ Fuel hose, 5 x 3 (di = Ø 5 mm)
- ⑥ Fuel pipe, 6 x 2 (di = Ø 2 mm)
- ⑦ Fuel pipe, 4 x 1 (di = Ø 2 mm)
- ⑧ Fuel hose, 3,5 x 3 (di = Ø 3.5 mm),
ca. 50 mm long
- ⑨ Fuel hose, 5 x 3 (di = Ø 5 mm), ca. 50 mm long
- ⑩ Fuel pipe, 4 x 1.25 (di = Ø 1.5 mm)
- ⑪ Connection fitting, da = Ø 4 mm

Permissible pipe lengths for petrol heater

Intake side	Pressure side
a = max. 2 m	b = max. 4 m

Permissible pipe lengths for diesel heater

Intake side	Pressure side
a = max. 5 m	• For suction pipe, di= Ø 2 mm b = max. 6 m
	• For suction pipe, di= Ø 5 mm b = max. 10 m

Please note!

Items ② ⑦ ⑪ are not included in the „tank connection“ setup kit, see additional parts catalogue for Order No.

Item ⑤ is not included in the „installation set“, see additional parts catalogue for order no.



Caution!

Safety instructions for the fuel supply

- The fuel must not be conveyed by gravity or overpressure in the fuel tank.
- Withdrawal of the fuel after the vehicle's fuel pump is not allowed.
- When the pressure in the fuel pipe is more than 0.2 bar to max. 4.0 bar, use a pressure reducer (order no. 22 1000 20 08 00) or a separate tank connection.
- When the pressure in the fuel pipe is more than 4.0 bar or there is a non-return valve in the return pipe (in the tank), a separate tank connection must be used.
- When using a T-piece in a plastic pipe, always use support sleeves in the plastic. Connect the T-piece and the plastic pipe with corresponding fuel hoses and secure with hose clips.

3 Installation

Fuel supply

Installation position of the dosing pump

Always mount the dosing pump with the pressure side rising upwards.

Every installation position over 15° is allowed, although an installation position between 15° and 35° is preferable.

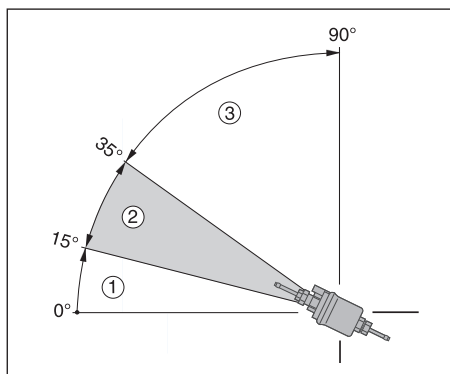

- ① Installation position between 0° – 15° is not allowed.
- ② Preferred installation position in range 15° to 35°.
- ③ Installation position in range 35° to 90° is allowed.

Possible suction and pressure height of the dosing pump

Pressure height from vehicle tank to dosing pump:

a = max. 3000 mm

Intake height in pressure-less vehicle tank:

b = max. 500 mm for petrol

b = max. 1000 mm for diesel

Intake height in vehicle tanks with withdrawal by negative pressure (valve with 0.03 bar in tank cap):

b = max. 150 mm for petrol

b = max. 400 mm for diesel

Pressure height of the dosing pump to the heater:

c = max. 2000 mm

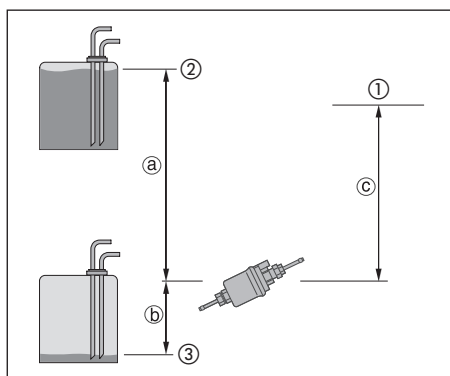

- ① Connection to heater
- ② Max. fuel level
- ③ Min. fuel level

Please note!

Check tank venting.



Caution!

Safety instructions for installing the dosing pump

- Always mount the dosing pump with the pressure side rising upwards – minimum incline 15°.
- Protect the dosing pump and filter from intolerable heat, do not mount near to the silencers and exhaust pipes.



3 Installation

Fuel supply

Fuel quality

The heater can easily run on the commercially available fuel you use for your engine.

Fuel for special cases

In special cases (above 0 °C), the heater can also run on fuel oil EL or paraffin.

Fuel for low temperatures

Refineries and fuel service stations automatically adjust the fuel to normal winter temperatures (winter diesel).

This means that difficulties are only to be expected for extreme drops in temperature, as also apply to the vehicle engine. Please also refer to the vehicle manual.

If the heater is run from a separate tank, please comply with the following rules:
For temperatures above 0 °C, any kind of diesel fuel as per DIN EN 590 can be used.

If no special diesel fuel is available for low temperatures, then paraffin or petrol should be mixed with the fuel according to the following table:

Temperature	Winter diesel	Addition
0 °C to -25 °C	100 %	-
-25 °C to -40 °C	50 %*	50 % paraffin or petrol

* or 100 % special cold diesel fuel (Arctic diesel)

Operation with bio diesel (PME)

The D 1 L C compact heater is certified for operation with bio diesel as per DIN V 51606 in flowing state.

Please note!

- The flowability of bio diesel reduces at temperatures below 0 °C.
- When using 100 % bio diesel, the heater should be operated twice a year with diesel fuel (in the middle and at the end of a heating period) to burn off any possible PME deposits. To do so, let the vehicle tank run almost empty and fill with diesel fuel without adding any bio diesel. While running on this tank filling, switch the heater on 2 to 3 times for 30 minutes at a time at the highest temperature setting.
- When operating with diesel / bio diesel mixtures of up to 50 % bio diesel, intermediate operation with pure diesel fuel is not necessary.

Please note!

- Mixtures with used oil are not allowed!
- The fuel lines and the metering pump must be filled with new fuel by, after refuelling with winter or low-temperature diesel or the mixtures listed, by running the heater for 15 minutes!

4 Operation and function

Operating instructions

The heater is operated by a control element.

- The control unit is used to switch the heater on and off and to set the required room temperature. The green LED display installed serves as a check whether the heater is on.
- The time switch can be used to immediately switch the heater on and off or to preselect the switch-on point.

Please note!

The control elements (e.g. mini timer, module timer) are accompanied by detailed operating instructions which you will receive from the company installing the heater.

Important instructions for operation

Safety checks before the start

After a longer interval in operations (after the summer months) the fuse must be put in position and / or the heater connected up to the battery.

Check that all parts fit firmly (tighten screws where necessary).

Check the fuel system visually for any leaks.

Heating at high altitudes

When using the heater at high altitudes, please note:

- Heating at altitudes up to 1500 m:
 - Unlimited heating possible.
- Heating at altitudes over 1500 m:
 - Heating is possible for short periods at this altitude (e.g. driving over a mountain pass or taking a break in a journey).
 - in the event of a lengthy stay, e.g. winter camping, it is necessary to adjust the fuel supply to the altitude, please contact a JE partner for further information.

Please note!

In diesel heaters, 12 volt, it is possible to install an altitude pump kit (Order No.: 24 0221 00 00 00), which allows the heater to be run at altitudes over 1500 m and up to 2750 m, even during a lengthy stay.

Initial commissioning

- After installation of the heater, the coolant circuit and the whole fuel supply system must be vented carefully. Comply with the instructions issued by the vehicle manufacturer.
- During the trial run of the heater, check all water and fuel connections for leaks and firm fitting.
- If the heater shows a fault during operation, find and eliminate the cause of the fault using a diagnosis unit.



4 Operation and function

Description of functions

Switching on

When the heater is switched on, the control lamp in the control element lights up. The glow plug is switched on and the fan starts at low speed.

Please note!

If there is still too much residual heat in the heat exchanger from when the heater was last used, firstly only the fan starts up (cold blowing).

Once the residual heat has been cleared, the heater starts.

Start

After approx. 15 seconds the fuel supply starts and the fuel / air mixture in the combustion chamber ignites.

After the flame has been detected the glow plug is switched off.

Fast heating up takes place in the „POWER“ control step, with maximum heat flow until the heat exchanger has reached its operating temperature.

Temperature selection with the control element

Select the required passenger compartment temperature with the knob. The temperature setting can be between +10 °C and +30 °C depending on the size of the room being heated and the prevailing outside temperature.

The required setting of the knob is an empirical value.

Control in heating mode

During the heating mode, the room temperature or the temperature of the sucked in heating air is constantly measured.

If the temperature is greater than the temperature preselected at the control element, the heater changes the heater to the „LOW“ step and then runs with a lower fan speed.

If the heat flow in the „Low“ control step no longer suffices, the heater switches to the „Medium“ control step.

The fan continues to run at a low speed.

In most cases the „Low-Medium-Low“ control at a low speed will cover the required heating requirements.

If the heat flow in the „Medium“ control step is insufficient, the heater switches back to the „High“ control step.

This in turn requires the full fan speed.

If the set temperature is still exceeded in the smallest control stage, the heater goes to the „OFF“ stage with the fan running on for approx. 4 minutes to cool of.

Then the fan continues at minimum speed (circulation mode) or is switched off (fresh air mode) until the heater is started again.

The restart takes place in the „Medium“ control step at a low fan speed.

Switching off

When the heater is switched off, the control lamp goes off and the fuel supply is switched off.

The fan runs on for approx. 3 minutes to cool down.

While the fan is running on, the glow plug is switched on for approx. 15 seconds to clean.

Special case:

If no fuel has been supplied or if the heater is in the „OFF“ stage until it is switched off, the heater is stopped without any after running.

4 Operation and function

Control and safety devices

- If the heater does not ignite within 90 seconds after starting the fuel pump, the start is repeated. If the heater still does not ignite after another 90 seconds of pumping fuel, the heater is switched off, i.e. the fuel supply is off and the fan runs on for approx. 3 minutes. After an unacceptable number of failed start attempts, the controller is locked.
- If the flame goes off by itself during operation, the heater is restarted. If the heater does not ignite within 90 seconds after the fuel pump has started, or ignites and goes off again within 15 minutes, the heater is switched off, i.e. the fuel supply is off and the fan runs on for approx. 3 minutes. This status can be remedied by briefly switching off and on again. Do not repeat the switching off / on routine more than twice.
- In the case of overheating, the combined sensor (flame sensor / overheating sensor) triggers, the fuel supply is interrupted and the heater switched off. Once the cause of the overheating has been eliminated, the heater can be re-started by switching off and on again. After an unacceptable number of failed start attempts, the controller is locked.
- If the lower or upper voltage limit is reached, the heater is switched off after 20 seconds.
- The heater does not start up when the glow plug is defect or when the electric lead to the dosing pump is interrupted.
- When the heater is switched off, the glow plug is switched on for 20 seconds (after glowing) while the fan runs on to clean off any combustion residues.

Please note!

Do not repeat the switching off / on routine more than twice.

Forced shut-down for ADR / ADR99 operation

In vehicles for the transport of dangerous goods (e.g. tanker trucks), the heater must be switched off before the truck drives into a danger area (refinery, fuel service station, etc.)

Failure to comply results in the heater switching off automatically when:

- The vehicle engine is switched off.
- An additional unit is started up (e.g. auxiliary drive for unloading pump etc.).
- A vehicle door is opened (ADR99 regulation, only in France).

The fan then runs on for max. 40 seconds.

Emergency shutdown – EMERGENCY OFF

If an emergency shutdown – EMERGENCY OFF – is necessary during operation, proceed as follows:

- Switch the heater off at the control element or
- pull the fuse out or
- disconnect the heater from the battery.



5 Electrical system

Heater wiring



Caution!

Safety instructions!

The heater must be electrically connected in accordance with the manufacturer's instructions. Incorrect wiring can lead to faults, for this reason the following notes must always be followed:

- Ensure that the insulation of electrical cables is not damaged. Avoid: chafing, kinking, jamming or exposure to heat.
- In waterproof connectors, seal any connector chambers not in use with filler plugs to ensure they are dirt-proof and water-proof.
- Electrical connections and ground connections must be free of corrosion and firmly connected.
- Lubricate connections and ground connections outside the heater interior with contact grease.

Please note!

Comply with the following when wiring the heater and the control element:

- Electrical leads, switchgear and controllers must be arranged in the vehicle so that they can function perfectly under normal operating conditions (e.g. heat exposure, moisture etc.)
- The following cable cross sections are to be used between the battery and heater. This ensures that the max. tolerable voltage loss in the cable does not exceed 0.5 V for 12 V or 1 V for 24 V rated voltage. Cable cross sections for a cable length of:
 - up to 5 m (plus cable + minus cable) = cable cross section 4 mm²
 - from 5 m to 8 m (plus cable + minus cable) = cable cross section 6 mm²
- If the plus cable is to be connected to the fuse box (e.g. terminal 30), the vehicle cable from the battery to the fuse box must be included in the calculation for the total cable length and re-dimensioned if necessary.
- Insulate unused cable ends.

Parts list for heater circuit diagrams

- 1.1 Burner engine
- 1.2 Glow plug
- 1.5 Overheating sensor
- 1.12 Flame sensor
- 2.1 Controller
- 2.2 Dosing pump
- 2.7 Main fuse
 - 12 volt = 25 A
 - 24 volt = 15 A
- 2.7.1 Fuse, actuation 5 A
- 5.1 Battery
 - 5.2.1 Battery operating switch (operation, e.g. controlled by the ignition key)
 - 5.2.2 Battery disconnecter (Emergency OFF function for ADR / ADR99)
- 5.3 Auxiliary drive HA+
 - 5.3.1 Switch, auxiliary drive
- 5.5 Generator D+
 - a) Connection of the control element and external sensor according to the „control elements“ circuit diagram
 - rt Power supply, plus – terminal 30
 - ge Switch-on signal – S+
 - gr Actual temperature
 - wsrt Switch off the anti-theft alarm system (ADR / ADR99 – feedback signal for timer switch)
 - br Power supply, minus – terminal 31
 - blws Diagnosis
 - grtt Nominal temperature
 - brws Ground connection for external temperature sensor and nominal temperature
 - b) Option
 - Vehicle fan control and / or
 - separate fresh air fan
 - c) Wiring for operation ADR / ADR99 (HGV vehicle transporting dangerous goods, e.g. tanker truck)
 - d) When only one switching element is used for item 5.2.1 and 5.2.2 it must be ensured that on activating the function „open the battery separating switch“ (EMERGENCY OFF function for ADR / ADR99 etc.), the switch always separates immediately (regardless of the heater status) and all the heater circuits are disconnected from the battery.

Please note!

- The circuit diagrams are printed at the end of this manual.
- Connectors and bush housings are shown from the cable inlet side.

5 Electrical system

Parts list for control element circuit diagrams

- 2.15.1 Temperature sensor, external (room temperature)
- 2.15.9 Temperature sensor (external temperature)

- 3.1.11 Control unit
- 3.1.12 Mini timer
- 3.1.14 Mini clock, 12 V, continuously lit
- 3.1.16 Button radio remote control
- 3.1.18 Button *CALLTRONIC*

- 3.2.8 Module timer (ADR / ADR99 – potentiometer)

- 3.3.6 TP41i radio remote control
- 3.3.7 TP5 radio remote control
- 3.3.8 Remote control *CALLTRONIC*

- 3.8.3 Antenna

- 3.9.1 Diagnosis, JE diagnosis

- a) Connection for control elements
 - rt Power supply, plus – terminal 30
 - ge Switch-on signal – S+
 - gr Actual temperature
 - wsrt Switch off the anti-theft alarm system (ADR / ADR99 – feedback signal for timer switch)
 - br Power supply, minus – terminal 31
 - blws Diagnosis
 - grrt Nominal temperature
 - brws Ground connection for external temperature sensor and nominal temperature
- b) Terminal 15
- c) Lighting, terminal 58
- d) Connection, diagnosis device
- e) External temperature sensor connection
- f) Cable bridge not used for ADR / ADR99
- g) Connection, external heating button
- h) Connection, radio module
- i) Connection, feedback signal from controller only for ADR / ADR99
- j) Connection, temperature sensor (external temperature), not for ADR / ADR99
- k) When connecting timer switch or radio receiver
Disconnect the cable here
- z) Lighting, terminal 58

Cable colours

- sw = black
- ws = white
- rt = red
- ge = yellow
- gn = green
- vi = violet
- br = brown
- gr = grey
- bl = blue
- li = purple

Please note!

- The circuit diagrams are printed at the end of this manual.
- Connectors and bush housings are shown from the cable inlet side.



6 Troubleshooting / maintenance / service

If any faults occur, please check the following items

- If the heater does not start after being switched on:
 - Switch the heater off and on again.
- If the heater still won't start, then check whether:
 - There is fuel in the tank?
 - The fuses are OK?
 - The electrical cables, connections etc. are OK?
 - Anything is clogging the combustion air supply or exhaust system?

Troubleshooting

If, after checking these items, the heater is still faulty or another malfunction occurs in your heater, please contact:

- If factory-installed, your contract workshop / garage.
- If subsequently installed, the workshop / garage which installed the heater.

Please note!

Please note that warranty claims can expire if the heater is modified by a third party or if non-original parts are installed.

Maintenance instructions

- Switch the heater off once a month for about 10 minutes, even outside the heating period.
- Before the heating period starts, the heater should undergo a trial run. If persistent extreme smoke develops, unusual burning noises or a clear fuel smell can be perceived or if electric / electronic parts heat up, the heater must be switched off and put out of service by removing the fuse. In this case, the heater should not be started up again until it has been checked by qualified staff who have been trained on Eberspächer heaters.
- Check the openings of the combustion air supply and exhaust system after longer standstill periods, clean if necessary!

Service

If you have any technical queries or problems with your pre-heater, dial the following service phone number:

Hotline
Phone 0800 / 1234300

Fax hotline
Phone 01805 / 262624

7 Environment

Certification

The high quality of Eberspächer's products is the key to our success.

To guarantee this quality, we have organised all work processes in the company along the lines of quality management (QM).

Even so, we still pursue a large number of activities for continuous improvement of product quality in order to keep pace with the similarly constantly growing requirements made by our customers.

All the steps necessary for quality assurance are stipulated in international standards.

This quality is to be considered in a total sense.

It affects products, procedures and customer/supplier relationships.

Officially approved public experts assess the system and the corresponding certification company awards a certificate.

Eberspächer has already qualified for the following standards:

**Quality management as per
DIN EN ISO 9001:2000 and ISO/TS 16949:1999**

**Environment management system as per
DIN EN ISO 14001:1996**

Disposal

Disposal of materials

Old devices, defect components and packaging material can all be separated and sorted into pure-grade fractions so that all parts can be disposed of as required in an environment-friendly manner recycled where applicable.

Electric motors, controllers and sensors (e.g. temperature sensors) are deemed to be „electronic scrap“.

Dismantling the heater

The heater is dismantled according to the repair stages in the current troubleshooting / repair instructions.

Packaging

The packaging of the heater can be kept in case it has to be sent back.

EU Declaration of Conformity

With regard to the following products

Heater type **Air heater 1L**
• **B 1 L C compact**
• **D 1 L C compact**

the product complies with the safety requirements stipulated in the directives of the EU Council for harmonization of the legal regulations of member states with regard to electromagnetic compatibility (89 / 336 / EEC).

This declaration applies to all products produced according to the production drawings for the aforementioned heaters – which are a part of this declaration.

The following standards/directives have been used to assess the product with regard to electromagnetic compatibility:

- EN 50081 – 1 Basic form interference emission.
- EN 50082 – 1 Basic form of interference immunity.
- 72 / 245 / EEC – Modification status 95 / 54 / EU interference suppression in motor vehicles.



8 Lists

A – Z index of key words

Key word	Page	Key word	Page
A		I	
Accident prevention	7	Information	4
ADR / ADR99	13, 28	Initial commissioning	26
Altitude	26	Installation area	16
Ambient temperature	10, 11	Installation location	13, 14
		Installation positions	15
B		Installation	13, 16
Bio diesel	25	Instructions	6, 7
		Interference suppression	10, 11
C			
Certificates	32	L	
Circuit diagrams (at the end of this manual)		List of abbreviations	34
Combustion air system	20		
Contents	2	M	
Control devices	28	Main dimensions	12
Control in heating mode	27	Maintenance	31
D		N	
Dangerous goods	13, 28	Nameplate	17
Declaration of conformity	32	Noise emission	10, 11
Description of functions	27		
Disposal	32	O	
Dosing pump	21 – 23	Operating instructions	26
		Operation	26
E			
Electronic system	29, 30	P	
Emergency off	28	Picture symbols	4
Emergency stop	28	PME	25
Environment protection	32	Power consumption	10, 11
EU Declaration of Conformity	32	Presentations	4
Exhaust system	19	Pressure height	24
Exhaust	19	Pressure side	22, 23
Extra parts	8	Purpose	4
F		R	
Fastening	16	Rated voltage	10, 11
Faults	31	Regulations	5, 6
Forced shut-down	28		
Formation of air bubbles	21	S	
Fuel extraction	22 – 23	Safety checks (before starting)	26
Fuel quality	25	Safety devices	28
Fuel	5, 21 – 25	Scope of supply	8, 9
		Start procedure	27
H		Statutory regulations	5, 6
Heat flow	10, 11	Storage temperature	10, 11
Heater air system	18	Suction height	24
Heating operation	26, 27	Switching off	27
Hotline	31	Switching on	27

8 Lists

List of key words A – Z

Keyword	Page
T	
Technical data	10, 11
Temperature selection	27
Test symbol	5
Text structure	4
T-piece	22
Transport	13
Troubleshooting	31
U	
Use of documentation	4
V	
Voltage limit	10, 11
Voltage	10, 11
W	
Weight	10, 11
Wiring	29

List of abbreviations

ADR

European agreement about the international transport of dangerous goods on the road.

ADR99

Dangerous goods regulations for France.

EC type approval

Permit awarded by the Federal Vehicle Office for the production of a heater for installation in motorised vehicles.

EMC Directive

Electromagnetic compatibility.

JE-partner

J. Eberspächer partner.

PME

Bio diesel as per DIN V 51606.



Circuit diagram for control elements

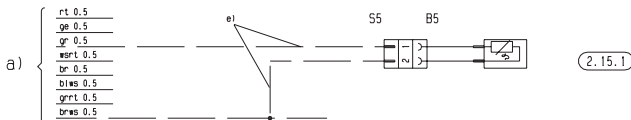
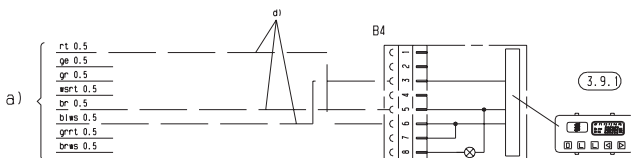
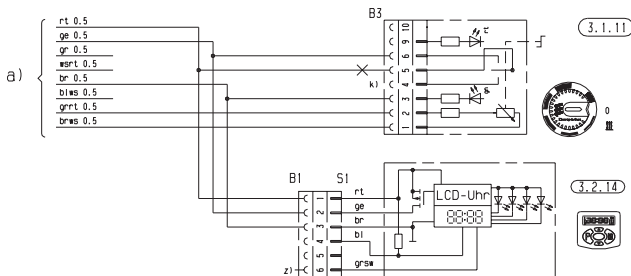
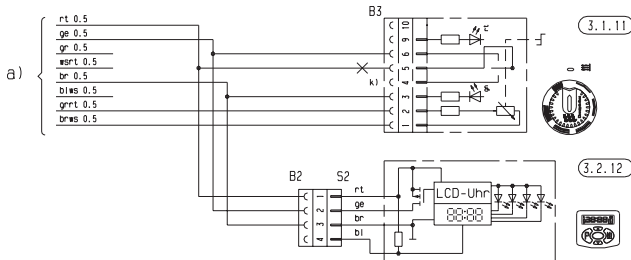
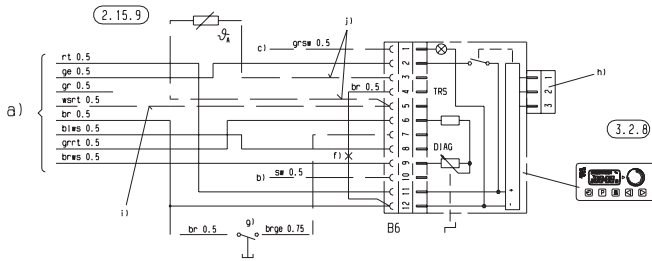

Circuit diagram for control elements

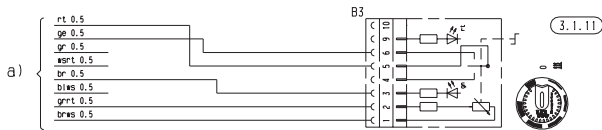
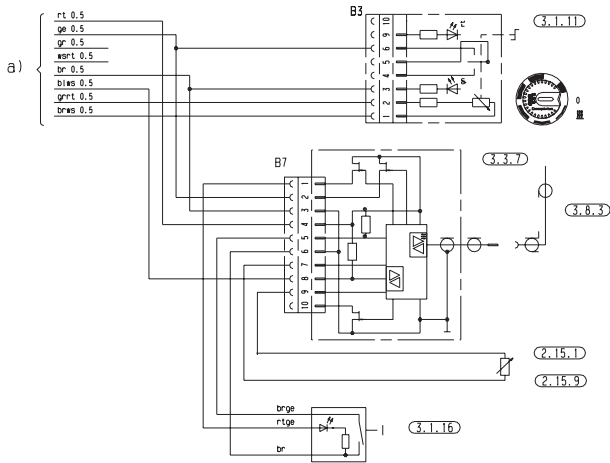

B7

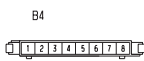
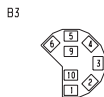

Circuit diagram for control elements

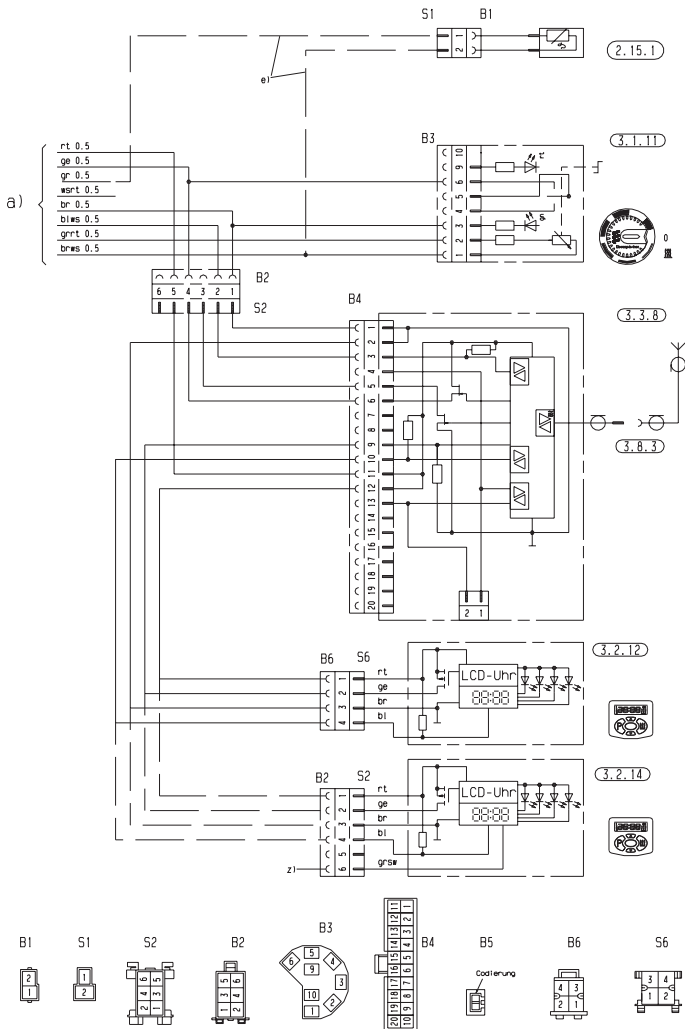



Circuit diagram for control elements

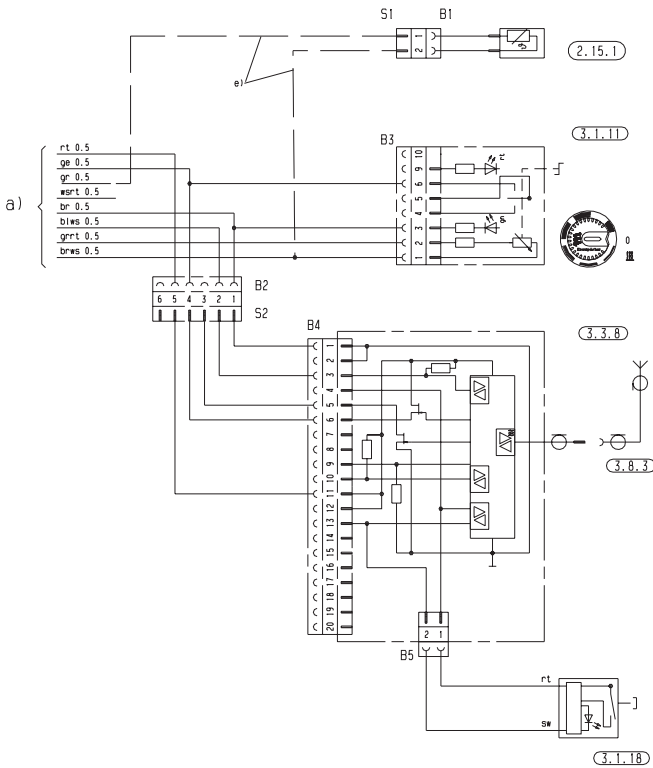



Circuit diagram for ADR / ADR99 control elements

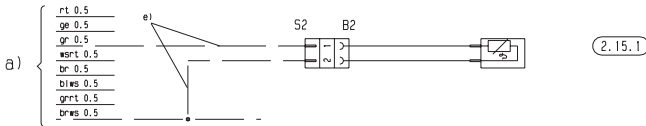
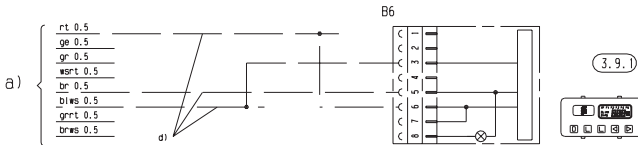
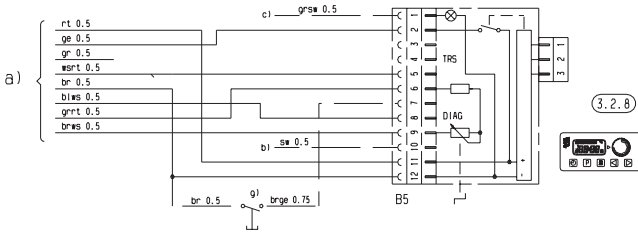
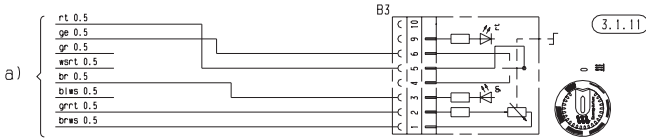

S2

B2

B3

B5

B6

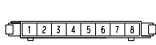

Schaltplan,
Bedienelemente
TRS

25 1895 00 97 04

