

Technical description
Installation instructions
Operating instructions
Maintenance instructions

J. Eberspächer
GmbH & Co. KG
Eberspächerstr. 24
D - 73730 Esslingen

Telefon (zentral)
(0711) 939 - 00
Telefax
(0711) 939 - 0500

www.eberspaecher.com

Heater (additional heater) for vehicles with petrol engine

Order no.

HYDRONIC B 5 W Z - 12 Volt 20 1818 05 00 00

Heater (additional heater) for vehicles with diesel engine

Order no.

HYDRONIC D 5 W Z - 12 Volt 25 2216 05 00 00

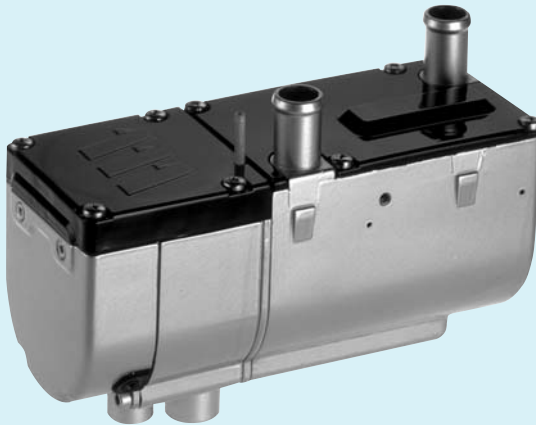

**Please give this manual to the customer
after installation of the heater.**

1 Introduction

Contents

Chapter	Title	Contents	Page
1	Introduction	<ul style="list-style-type: none"> • Contents 2 • Concept of this manual 3 • Special text structure, presentation and picture symbols 4 • Important information before starting work 4 • Statutory regulations 5, 6 • Safety instructions for installation and operation 6, 7 • Accident prevention 7 	
2	Product information	<ul style="list-style-type: none"> • Scope of supply 8, 9 • Technical data petrol heaters 10 • Technical data diesel heaters 11 • Main dimensions 12 	
3	Installation	<ul style="list-style-type: none"> • Installation and location 13 • Possible installation positions 14 • Mounting and fastening 14 • Nameplate 15 • Connection to the cooling water circuit 16, 17 • Exhaust system 18 • Combustion air system 19 • Fuel supply 20 – 24 	
4	Operation and function	<ul style="list-style-type: none"> • Operating instructions / important information for operation 25 • Initial commissioning 25 • Description of functions 25 • Control and safety devices 26 	
5	Electrical system	<ul style="list-style-type: none"> • Heater wiring 27 • Circuit diagram 28 	
6	Troubleshooting Maintenance Service	<ul style="list-style-type: none"> • Troubleshooting procedure 29 • Maintenance instructions 29 • Service 29 	
7	Environment	<ul style="list-style-type: none"> • Certification 30 • Disposal 30 • EU Declaration of Conformity 30 	
8	Guarantee conditions	<ul style="list-style-type: none"> • Guarantee 31 • Liability 31 • Place of jurisdiction 31 	
9	Lists	<ul style="list-style-type: none"> • List of key words 32, 33 • List of abbreviations 33 	



1 Introduction

Concept of this manual

This manual aims to support the service company installing the heater and to provide the user with all important information about the heater. The manual has been divided into 9 chapters to make it easier to find the corresponding information quickly.

1 Introduction

Here you will find important introductory information about installation of the heater and about the structure of the manual.

2 Product information

Here you will find information about the scope of supply, the technical data and the dimensions of the heater.

3 Installation

Here you will find important information and instructions referring to installation of the heater.

4 Operation and function

Here you will find information about the operation and function of the heater.

5 Electric system

Here you will find information about the electronic system and electronic components of the heater.

6 Troubleshooting / maintenance / service

Here you will find information about any necessary troubleshooting procedures, maintenance and the service hotline.

7 Environment

Here you will find information about certification and disposal of the heater together with the EU Declaration of Conformity.

8 Guarantee conditions

Here you will find the guarantee, the liability and the place of jurisdiction.

9 Lists

Here you will find the key word list and abbreviations list.

1 Introduction

Special text structure, presentation and picture symbols

This manual uses special text structures and picture symbols to emphasise different contents. Please refer to the examples below for the corresponding meanings and associated actions.

Special structure and presentations

A dot (•) indicates a list which is started by a heading. If an indented dash (–) follows a dot, this list is subordinate to the dot.

Picture symbols



Regulation!

This picture symbol with the remark "Regulation" refers to a statutory regulation. Failure to comply with this regulation results in expiry of the type permit for the heater and preclusion of any guarantee and liability claims on J. Eberspächer GmbH & Co. KG.



Danger!

This picture symbol with the remark "Danger!" refers to the risk of a fatal danger to life and limb. Failure to comply with these instructions can result in severe injuries under certain circumstances.



Caution!

This picture symbol with the remark "Caution!" refers to a dangerous situation for a person and/or the product.

Failure to comply with these instructions can result in injuries to people and/or damage to machinery.

Please note!

These remarks contain application recommendations and useful tips for installation of the heater.

Important information before starting work

Range of application of the heater

The heater operating independently of an engine is intended for installation in the following vehicles, depending on its heating output:

- Vehicles of all kinds
- Construction machinery
- Agricultural machinery
- Boats, ships and yachts

Please note!

The heater must not be installed in motor vehicles used to transport dangerous goods according to ADR / ADR 99.

Purpose of the heater (using the vehicle heat exchanger)

- Heat up the vehicle's water circuit together with the vehicle engine for adequate heating of:
 - Driver and working cabs
 - Freight compartments
 - Ship's cabins
 - Passenger and crew compartments
 - Vehicle engines and units

On account of its functional purpose, the heater is not permitted for the following applications:

- Long-term continuous operation, e.g. for pre-heating and heating of:
 - Residential rooms
 - Garages
 - Work huts, weekend homes and hunting huts
 - House boots, etc.



Caution!

Safety instructions for application and proper purpose

- The heater must only be used and operated for the range of application stated by the manufacturer in compliance with the "Operating instructions" included with every heater.



1 Introduction

Statutory regulations

The Federal Vehicle Office has awarded an "EU Type Permit" with an official test symbol for installation of the heater in motorised vehicles, shown on the heater nameplate.

HYDRONIC e100 0023



Regulation!

Directive 2001 / 56 / EU of the European Parliament and the Council

• Arrangement of the heater

- Parts of the structure and other components near the heater must be protected from excess heat exposure and possible contamination from fuel or oil.
- The heater must not pose a fire hazard even when it overheats.
This requirement is deemed to be fulfilled when adequate clearance to all parts is observed during installation, sufficient ventilation is provided and fire-proof materials or heat plates are used.
- The heater must not be located in the passenger compartment in vehicles of class M₁, M₂, M₃ and N. A unit may however be used in a hermetically sealed housing which also corresponds to the conditions stated above.
- The factory nameplate or duplicate must be affixed so that it can still be easily read when the heater is installed in the vehicle.
- All appropriate precautions must be taken when arranging the heater to minimise the risk of injuries to persons or damage to other property.

• Fuel supply

- The fuel intake connection must not be located in the passenger compartment and must be sealed with a properly closing lid to prevent any fuel leaks.
- In heaters for liquid fuel where the heater fuel is separate from the vehicle fuel, the type of fuel and intake connection must be clearly identified.
- A warning sign is to be fixed to the intake connection indicating that the heater must be switched off before refuelling.

• Exhaust system

- The exhaust outlet must be arranged so as to prevent any penetration of exhaust fumes into the vehicle interior through the ventilation system, warm air intakes or open windows.

• Combustion air intake

- The air for the heater combustion chamber must not be sucked in from the passenger compartment of the vehicle.
- The air intake must be arranged or protected in such a way that it cannot be blocked by other objects.

• Operating status display

- A clearly visible operating display in the user's field of vision must indicate when the heater is switched on and off.

1 Introduction

Statutory regulations

Please note!

- Compliance with the statutory regulations and safety instructions is prerequisite for guarantee and liability claims.
Failure to comply with the statutory regulations and safety instructions and incorrect repairs even when using original spare parts make the guarantee null and void and preclude any liability for J. Eberspächer GmbH & Co. KG.
- Subsequent installation of this heater must comply with these installation instructions.
- The statutory regulations are binding and must also be observed in countries which do not have any special regulations.
- Installation of the heater in special vehicles must comply with the regulations applying to such vehicles.
- Other installation requirements are contained in the corresponding sections of this manual.

Safety instructions for installation and operation



Danger!

Risk of injury, fire and poisoning!

- Disconnect the vehicle battery before starting any kind of work.
- Before working on the heater, switch the heater off and let all hot components cool down.
- The heater must not be used in closed rooms, e.g. in the garage or in a multi-storey car park (do not leave the engine running when the vehicle is at a standstill).



Caution!

Safety instructions for installation and operation!

- The heater must only be installed by a JE partner authorised by the manufacturer according to the instructions in this manual and possibly according to special installation recommendations; the same applies to any repairs to be carried out in the case of repairs or guarantee claims.
- Repairs by non-authorised third-parties or with not original spare parts are dangerous and therefore not allowed. They result in expiry of the type permit of the heater; consequently, when installed in motor vehicles they can cause expiry of the vehicle operating licence.
- The following measures are not allowed:
 - Changes to components relevant to the heater
 - Use of third-party components not approved by Eberspächer
 - Nonconformities in installation or operation from the statutory regulations, safety instructions or specifications relevant to safe operation as stated in the installation instructions and operating instructions. This applies in particular to the electrical wiring, fuel supply, combustion air system and exhaust system.



1 Introduction

Safety instructions for installation and operation



Caution!

Safety instructions for installation and operation

- Only the controls approved by Eberspächer may be used to operate the heater. The use of other controls can result in malfunctions.
 - Only when upgrading the additional heater: Before the heater is installed again in another vehicle, rinse the heater parts carrying water with clear water.
 - When carrying out electric welding on the vehicle, the plus pole cable at the battery should be disconnected and placed at ground to protect the controller.
 - The heater must not be operated where there is a risk of an accumulation of flammable vapours or dust, for example close to
 - fuel depot
 - coal depot
 - wood depot
 - grain depots etc.
 - The heater must be switched off when refuelling (vehicle engine).
 - When the heater is mounted in a safety housing etc., the installation compartment of the heater is not a stowage compartment and must be kept clear. In particular fuel canisters, oil cans, spray cans, gas cartridges, fire extinguishers, cleaning rags, items of clothing, paper etc. must not be stored or transported on or next to the heater.
 - Defect fuses must only be replaced by fuses with the prescribed rating.
 - If fuel leaks from the heater fuel system, arrange for the damage to be repaired immediately by a JE service partner.
- When topping up the coolant, only use the coolant permitted by the vehicle manufacturer, see the vehicle operating manual. Any blending with unpermitted coolant can cause damage to the engine and heater.
 - After-running of the heater must not be interrupted prematurely e.g. by pressing the battery disconnecting switch, apart from in the case of an emergency stop.

Accident prevention

General accident prevention regulations and the corresponding workshop and operation safety instructions are to be observed.

2 Product information

Scope of supply for petrol heaters

Picture No.	Quantity / Designation	Order number
- 1	<i>HYDRONIC</i> B 5 W Z – 12 V	20 1818 05 00 00
- 1	<i>HYDRONIC</i> D 5 W Z – 12 V	25 2216 05 00 00

Please note!

- Please consult the additional parts catalogue for any other parts required for installation, e.g. hose clips.
- The heater can be upgraded from additional heater to pre-heater with a mod kit. Please consult the sales documents for the order number for vehicle-specific mod kits.

as complete package:

1	1	Heater	----
2	1	Dosing pump	----

to be ordered separately:

3	1	Heater bracket	25 2220 80 00 01
4	1	Central screw	100 10 258
5	4	Metal-rubber puffer	20 1185 00 00 01
6	1	Water hose Ø 20	25 1917 80 00 01
7	2	Connector Ø 20 mm	20 1534 88 00 01
8	p.m.	Pipe 3,5x3	360 75 300
9	p.m.	Pipe 4x1,25	090 31 118
10	1	Pipe clip	22 1000 50 05 00
11	1	Hose clip	10 2064 01 60 25
12	1	Flexible exhaust pipe	25 1774 80 02 00
13	1	Combustion air hose	360 00 099
14	1	End sleeve	25 1688 80 12 01
15	1	Plug	22 1000 30 10 21
16	1	Receptacle housing	22 1000 31 87 00
17	1	Bracket	22 1000 50 03 00
18	1	T-piece 8-6-8	262 31 151
19	2	Support sleeve	22 1000 20 02 00
20	p.m.	Hose 7,5x2,5	360 31 070
21	p.m.	Hose 5x3	360 75 350
22	p.m.	Pipe 6x2	090 31 125
23	1	Safety holder	22 1000 31 06 00

Recommendation:

Starting the heater can be limited with an outside temperature switch, i.e. the heater switches on at a temperature < 5°C or < 10°C.

In addition, an ON/OFF switch should be fitted for vehicles frequently used for short distances.

This allows for the heater to be switched off with the ON/OFF switch when used for short distances and during the summer months.

The ON/OFF switch can be bought from a good parts dealer.

Outside temperature switch < 5°C

Outside temperature switch < 10°C

ON / OFF switch, 12 volt

Order number:

201 00 121

201 00 122

201 00 123

2 Product information

Scope of supply

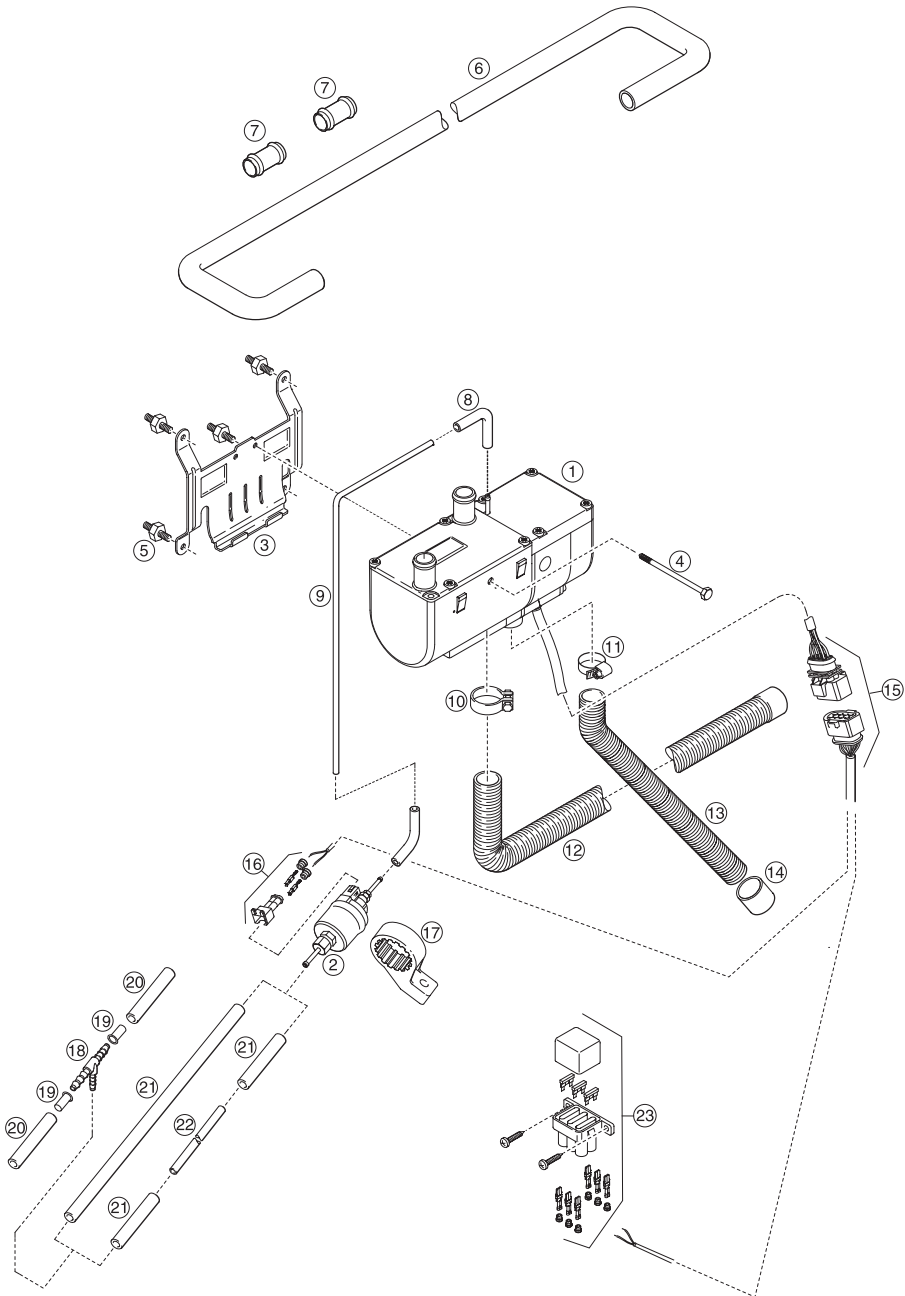

2 Product information

Technical data for petrol heaters

Heater		B 5 W Z	
Heating medium		Water, cooling fluid	
Control of the heat flow		Large	Small
Heat flow (watt)		5000	1500
Fuel consumption (l/h)		0,69	0,2
Mean electr. power (watt)	in operation	37	10
	at start	110	
	after-running	8	
Electr. power of water pump		16 watt	
Rated voltage		12 volt	
Operating range		10,2 volt	
<ul style="list-style-type: none"> • Lower voltage limit: an undervoltage protection in the controller switches the heater off on reaching approx 10 volt. 			
<ul style="list-style-type: none"> • Upper voltage limit: an overvoltage protection in the controller switches the heater off on reaching approx 10 volt. 		16 volt	
Tolerable operating pressure		up to 2,5 bar overpressure	
Flow rate of the water pump at 0.1 bar		800 l/h	
Minimum water flow rate of the heater		250 l/h	
Fuel (see also fuel supply, page 29)		commercially available petrol (DIN EN 228)	
Tolerable operating temperature	operation heater	-40 °C bis +80 °C	
	operating, dosing pump	-40 °C bis +20 °C	
	storage	-40 °C bis +105 °C	
Interference suppression class		5 for VHF, SW, MW, 2 for LW	
Weight			
<ul style="list-style-type: none"> • without controller and cooling fluid • with dosing pump and water pump, 		ca. 2,3 kg ca. 2,5 kg	



Caution!

Safety instructions for technical data!

Failure to comply with the technical data can result in malfunctions.

All technical data + 10%



2 Product information

Technical data for diesel heaters

Heater		D 5 W Z		
Heating medium		Water, cooling fluid		
Control of the heat flow		Large	Small	
Heat flow (watt)		5000	2400	
Fuel consumption (l/h)		0,62	0,27	
Mean electr. power (watt)	in operation	37	10	
	at start	110		
	after-running	8		
Electr. power of water pump		16 watt	16 watt	12 watt
Rated voltage		12 volt	12 volt	24 volt
Operating range		10,2 volt	10,2 volt	20,4 volt
• Lower voltage limit: an undervoltage protection in the controller switches the heater off on reaching approx 10 v.				
• Upper voltage limit: an overvoltage protection in the controller switches the heater off on reaching approx 10 v.		16 volt	16 volt	32 volt
Tolerable operating pressure		up to 2,5 bar overpressure		
Flow rate of the water pump at 0.1 bar		800 l/h	800 l/h	950 l/h
Minimum water flow rate of the heater		250 l/h		
Fuel (see also fuel supply, page 29)		commercially available diesel (DIN EN 590) PME (DIN V 51606) only for D 5 W S, 24 Volt		
Tolerable operating temperature	operation heater	-40 °C bis +80 °C		
	operating, dosing pump	-40 °C bis +80 °C		
	storage	-40 °C bis +105 °C		
Interference suppression class		5 for VHF, SW, MW, 2 for LW		
Weight		ca. 2,3 kg		
• without controller and cooling fluid		ca. 2,5 kg		
• with dosing pump and water pump,				



Caution!

Safety instructions for technical data!

Failure to comply with the technical data can result in malfunctions.

All technical data + 10%

DE

EN

2 Product information

Main dimensions

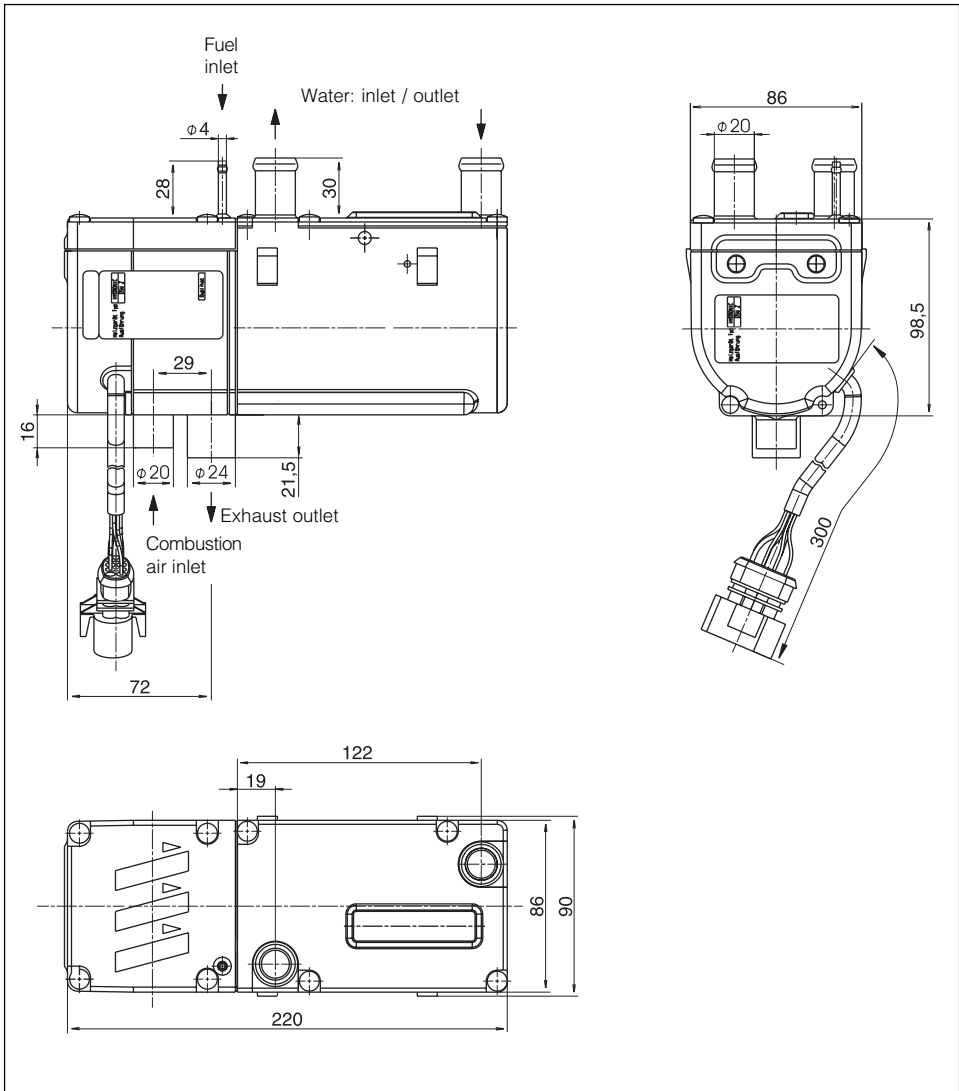

3 Installation

Installation location

The installation location for the heater is the engine compartment. The heater must be mounted below the min. cooling water level (compensation tank, cooler, vehicle heat exchanger) for automatic venting of the heat exchanger of the heater.

Please note!

- In a truck, the water heater is preferably fastened underneath the driver's cab in the longitudinal beam near the vehicle engine.
- The regulations and safety instructions to be observed for this chapter are stated on page 4 – 7.
- The installation suggestions made in the installation instructions are examples. Other installation locations are possible if they correspond to the installation requirements stated in these installation instructions.
- Other installation information (e.g. for boats and ships) is available from the manufacturer on request.

Installation example

Petrol heater / diesel heater in a car

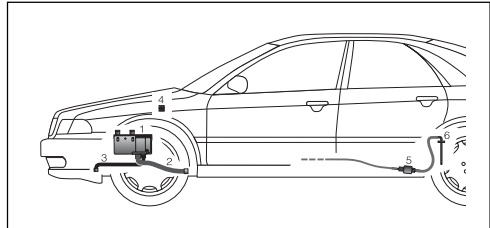

- ① heater
- ② exhaust pipe
- ③ combustion air intake silencer
- ④ fuse bracket
- ⑤ dosing pump
- ⑥ rising pipe

Installation example

Diesel heater in a truck and in a delivery van

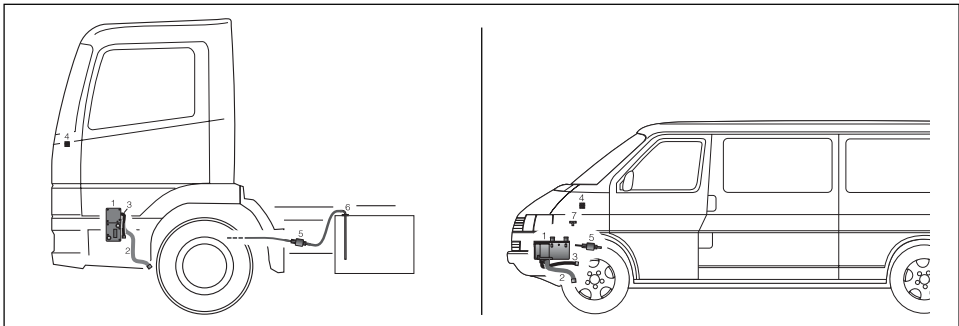

- ① Heater
- ② Exhaust silencer
- ③ Combustion air hose
- ④ Fuse holder
- ⑤ Dosing pump
- ⑥ Rising pipe
- ⑦ T-piece

3 Installation

Possible installation positions

The heater should preferably be installed in the normal position, horizontal with the exhaust connection down to the bottom. Depending on the installation conditions, the heater can also be mounted in the permitted swivel range, see diagram.

When the heater is operating, the shown normal or maximum installation positions can be varied briefly by up to $+15^\circ$ in all directions. Such deviations caused by the inclined position of the vehicle do not impair the heater functions in any way.

Heater in normal position with permitted swivel range

Swivel range from the normal position up to max. 90° swivel upwards.

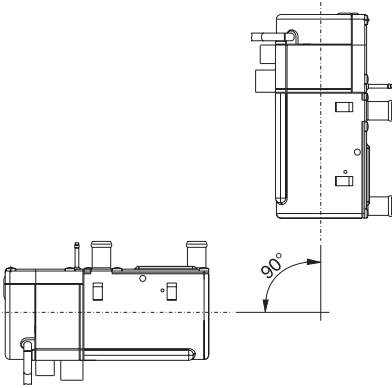

Swivel range from the normal position to max. 90° swivel around the longitudinal axis.

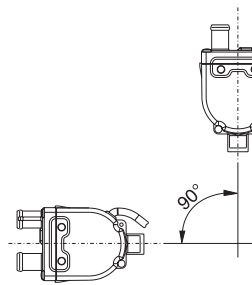

Mounting and fastening

Position the heater in the holding clips of the heater bracket and fasten with fastening screw, M6x97 (torque $6^{0.5}\text{Nm}$). Mount the heater bracket in a suitable position in the engine compartment, possibly using anti-vibration pads if necessary.

Please note!

Depending on the installation space available, the heater can be moved sideways in the bracket and screwed in one of the two fastening threads.

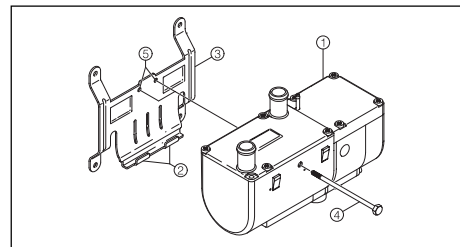

- ① heater
- ② bracket clips
- ③ bracket holder
- ④ fastening screw
- ⑤ fastening thread

3 Installation

Nameplate

The nameplate is fastened to the front of the heater. The second nameplate (duplicate) is included in the scope of supply of the heater.

If required, the duplicate nameplate can be adhered in a clearly visible position on the heater or near to the heater.

Please note!

The regulations and safety instructions to be observed for this chapter are stated on page 5.

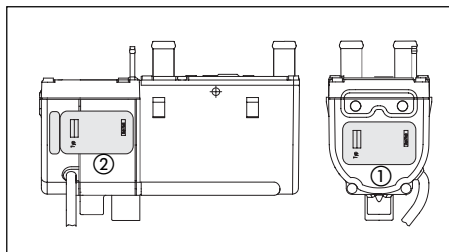

- ① Original nameplate
- ② 2nd nameplate (duplicate)

3 Installation

Connection to the cooling water circuit

The heater is connected to the cooling water circuit in the water feed pipe from the vehicle engine to the heat exchanger. There are four possible alternative installations here.



Danger!

Risk of injuries and burns!

It is possible for the coolant and components of the coolant circuit to get very hot.

- Parts conveying water must be routed and fastened in such a way that they pose no temperature risk to man, animals or material sensitive to temperature from radiation / direct contact.
- Before working on the coolant circuit, switch the heater off and wait until all components have cooled down completely, if necessary where safety gloves.

Please note!

- When installing the heater and the water pump, please note the direction of flow of the coolant circuit.
- Fill the heater and water hoses with coolant before connecting to the coolant circuit.
- Route the water hoses without any kinks, and in a rising position if possible.
- When routing the water pipes, observe a sufficient clearance to hot vehicle parts.
- Protect all water hoses/water pipes from chafing and from extreme temperatures.
- Secure all hose connections with hose clips.
- After the vehicle has been operating for 2 hours or travelled 100 km, tighten the hose clips again.
- The minimum water flow rate is only guaranteed if the temperature difference of the heating medium does not exceed 10 K between water inlet and water outlet during heating.
- Only overpressure valves with an opening pressure of min. 0.4 – max. 2 bar may be used in the coolant circuit.
- The coolant liquid must contain at least 10% antifreeze all year round as corrosion protection.
- The cooling liquid must contain sufficient antifreeze for low temperatures.
- Before commissioning the heater or after changing the cooling liquid, the whole coolant circuit including heater must be vented free of bubbles according to the instructions issued by the vehicle manufacturer.
- Only top up with coolant approved by the vehicle manufacturer.

3 Installation

Connection to the cooling water circuit

Integrate the heater in the water feed pipe from the vehicle engine to the heat exchanger "inline connection"

Disconnect the water feed pipe from the vehicle engine to the vehicle heat exchanger. Connect up the heater with connection pieces and water hoses to the water feed pipe.

Route and connect a water hose from the pressure connection of the water pump to the water intake connection of the heater.

Secure both connection parts with hose clips.

Heating characteristics

The heater starts in the "large" setting. Once the cooling water temperature has reached approx. 80°C, depending on the selected fan setting, the heater switches to the "small" setting.

If the heating output is inadequate in the "small" setting, the cooling water temperature falls to 75°C: the heater then switches back to the "large" settings.

If the heating output is sufficient in the "small" setting, the cooling water temperature increases to 85°C: the heater switches to the pause setting. Once the cooling water has cooled down to 75°C in the pause setting, the cycle starts up again in the "large" setting.

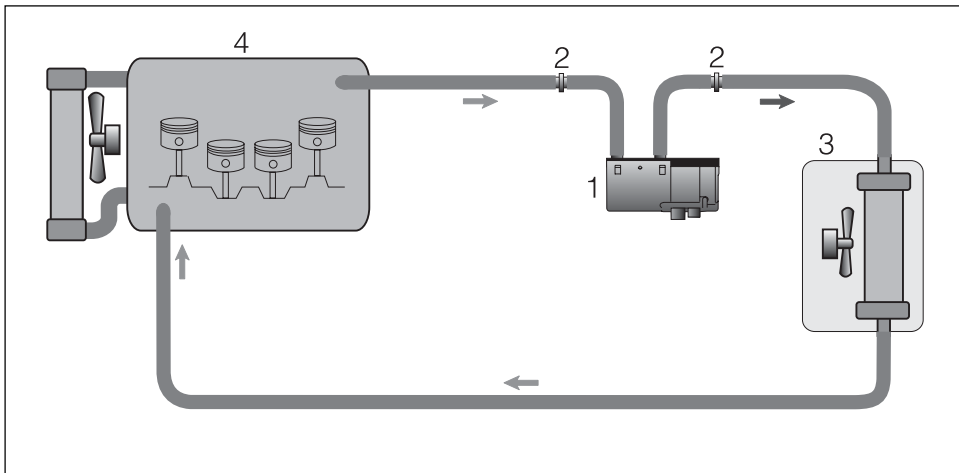

- ① heater
- ② connection piece
- ③ heat exchanger
- ④ vehicle engine

3 Installation

Exhaust system

(Exhaust diagram see page 19).

Mounting the exhaust system

The scope of supply of the universal installation kit includes a flexible exhaust pipe, inner Ø 24 mm, 1000 mm long and an exhaust silencer.

The flexible exhaust pipe can be shortened to 20 cm or lengthened to max. 2 m, depending on the installation conditions.

Fasten the exhaust silencer to a suitable position in the vehicle. Route the flexible exhaust pipe from the heater to the exhaust silencer and fasten with pipe clips. If necessary, also fasten the flexible exhaust pipe with pipe clips at suitable positions in the vehicle. Connect the exhaust end pipe to the exhaust silencer with an end sleeve and fasten with a pipe clip.



Caution!

Safety instructions!

The whole exhaust system gets very hot during and immediately after the heater has been working in the heating mode. This is why the exhaust system must be routed according to these installation instructions.

- The exhaust outlet must end in the open air.
- The exhaust pipe must not protrude beyond the lateral limits of the vehicle.
- Install the exhaust pipe sloping slightly downwards. If necessary, make a drain hole approx. Ø 5 mm at the lowest point to drain off condensation.
- Important functional parts of the vehicle must not be impaired (keep sufficient clearance).
- Mount the exhaust pipe with sufficient clearance to heat-sensitive parts. Pay particular attention to fuel pipes (plastic or metal), electrical cables and brake hoses etc.!
- Exhaust pipes must be fastened safely (recommended clearance of 50 cm) to avoid damage from vibrations.
- Route the exhaust system so that the emitted fumes are not sucked in with the combustion air.
- The mouth of the exhaust pipe must not get clogged by dirt and snow.
- The mouth of the exhaust pipe must not point in the direction of travel.
- Always fasten the exhaust silencer to the vehicle.



Danger!

Risk of injuries and burns!

Every type of combustion produces high temperatures and toxic exhaust fumes. This is the reason why the exhaust system must be installed according to these instructions.

- Do not perform any work on the exhaust system while the heater is working.
- Before working on the exhaust system, first switch the heater off and wait until all parts have cooled down completely, wear safety gloves if necessary.
- Do not inhale exhaust fumes.

Please note!

- Comply with the regulations and safety instructions for this chapter on page 4 – 7.
- If a silencer is fitted, the exhaust end pipe must be much shorter than the flexible exhaust pipe between the heater and the exhaust silencer.

3 Installation

Combustion air system

Mounting the combustion air system

The heater is mounted in the engine compartment, as described in these instructions.

If the intake connection for combustion air is in a position where the combustion air can be expected to be no warmer than 25°C and where neither splashed water nor dust/dirt are expected, then no combustion air hose is required.

Otherwise a flexible combustion hose must be mounted with an inner \varnothing 20 mm and up to 1.5 m long, to ensure that the intake of combustion air comes from an area which complies with the above conditions.

After completing all work, push an end sleeve over the intake silencer/flexible pipe.

Please note!

Comply with the regulations and safety instructions for this chapter on page 4 – 7.



Caution!

Safety instructions for the combustion air system

- The combustion air opening must be free at all times.
- Position the combustion air intake to be sure that exhaust fumes cannot be sucked in with the combustion air.
- The combustion air intake must not get clogged with dirt and snow.
- Install the combustion air intake system sloping slightly downwards. If necessary, make a drain hole approx. \varnothing 5 mm at the lowest point to drain off condensation.

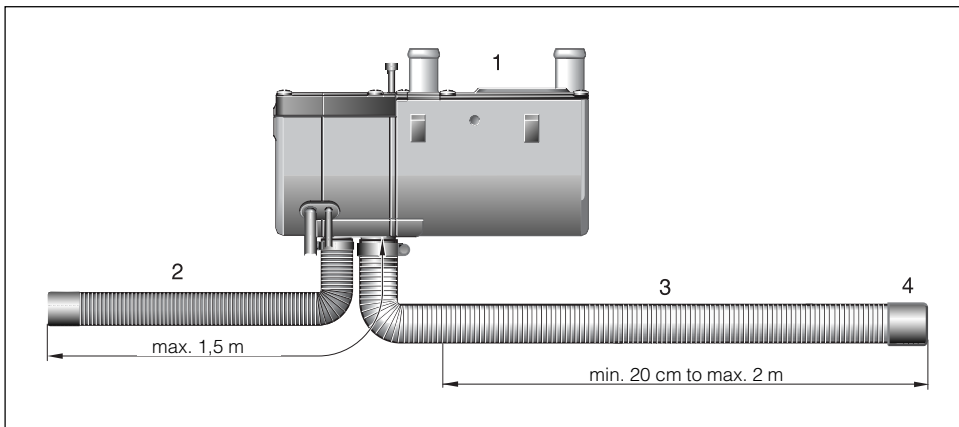

- ① heater
- ② combustion air pipe
- ③ exhaust pipe
- ④ end sleeve

3 Installation

Fuel supply

Mounting the dosing pump, routing the fuel pipes and mounting the fuel tank

The following safety instructions must be observed when mounting the dosing pump, routing the fuel pipes and mounting the fuel tank.

Deviations from the instructions stated here are not allowed.

Failure to comply can result in malfunctions.



Danger!

Risk of fire, explosion, poisoning and injuries!

Caution when handling fuel.

- Switch off the vehicle engine and heater before refuelling and before working on the fuel supply.
- No naked lights when handling fuel.
- Do not smoke.
- Do not inhale petrol fumes.
- Avoid any contact with the skin.



Caution!

Safety instructions for routing the fuel pipes!

- Only use a sharp knife to cut off fuel hoses and pipes. Interfaces must not be crushed and must be free of burrs.
- The fuel pipe from the dosing pump to the heater should be routed at a continuous rise.
- Fuel pipes must be fastened safely to avoid any damage and/or noise production from vibrations (recommended clearance of approx. 50 cm).

- Fuel pipes must be protected from any mechanical damage.
- Route the fuel pipes so that any distortion of the vehicle, engine movements etc. cannot have any lasting effect on the service life.
- Parts carrying fuel must be protected from interfering heat.
- Never route or fasten the fuel pipes to the heater or vehicle exhaust system. When the systems cross, always ensure there is a sufficient heat clearance. If necessary, install heat deflection plates.
- Dripping or evaporating fuel must never be allowed to collect on hot parts or ignite on electric systems.
- When connecting fuel pipes with a fuel hose, always mount the fuel pipes in a butt joint to prevent any bubbles from forming.

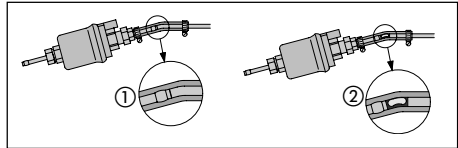

- ① correct connection
② incorrect connection – bubble formation.

Safety instructions for fuel pipes and fuel tanks in buses and coaches

- In buses and coaches, fuel pipes and fuel tanks must not be routed through the passenger compartment or driver's cab.
- Fuel tanks in buses and coaches must be positioned in such a way that the exits are not in direct danger from a possible fire.

Please note!

Comply with the regulations and safety instructions for this chapter on page 4 – 7.

3 Installation

Fuel supply for petrol heaters

Fuel feed point with T-piece from the fuel supply line from the tank fitting to the vehicle engine.

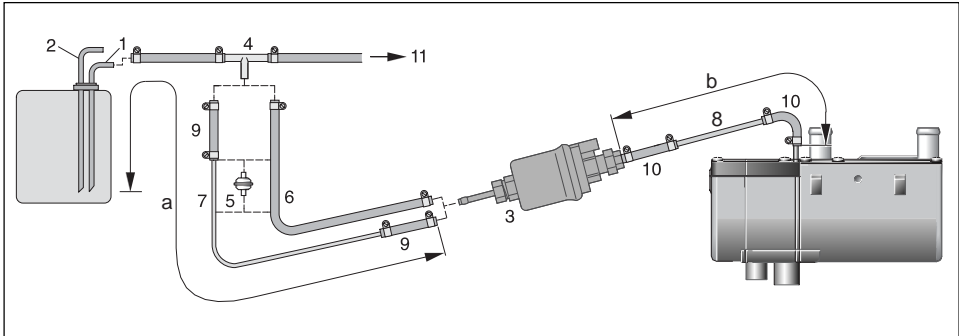

- ① fuel feed pipe from tank connection – insert T-piece before the fuel pump in the fuel feed pipe
- ② fuel return pipe to the tank connection
- ③ dosing pump
- ④ T-piece, 8-6-8
- ⑤ fuel filter – only necessary for contaminated fuel
- ⑥ fuel hose, 5 x 3 (di = Ø 5 mm)
- ⑦ fuel pipe, 6 x 2 (di = Ø 4 mm)
- ⑧ fuel pipe, 4 x 1.25 (di = Ø 2 mm)
- ⑨ fuel hose, 5 x 3 (di = Ø 5 mm), approx. 50 mm long
- ⑩ fuel hose, 3.5 x 3 (di = Ø 3.5 mm), approx. 50 mm long
- ⑪ to the engine, mechanical fuel or injection pump

Possible pipe lengths

Intake side
a = max. 2 m

Pressure side
b = max. 4 m for petrol
b = max. 6 m for diesel

Installation position of the T-piece

Use the installation positions shown in the diagram when inserting a T-piece

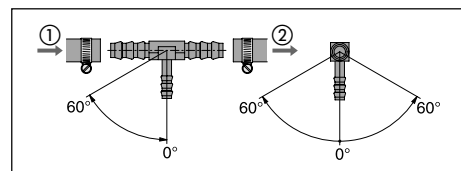

- ① direction of flow from the fuel tank
- ② direction of flow to the vehicle engine

3 Installation

Fuel supply for petrol heaters

Fuel feed point with tank connection – ascending pipe, integrated in the vehicle tank

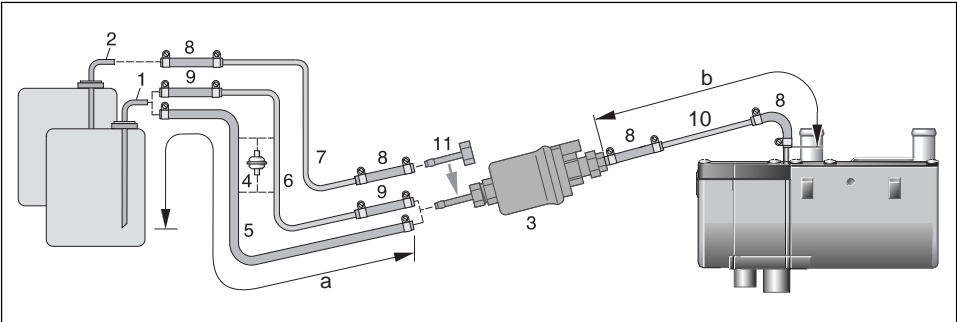

- ① tank connection for metal tank –
di = Ø 2 mm, da = Ø 6 mm
- ② tank connection for tank fitting –
di = Ø mm, da = Ø 4 mm
- ③ dosing pump
- ④ fuel filter – only required for contaminated fuel
- ⑤ fuel hose, 5 x 3 (di = Ø 5 mm)
- ⑥ fuel pipe, 6 x 2 (di = Ø 2 mm)
- ⑦ fuel hose, 4 x 1 (di = Ø 2 mm)
- ⑧ fuel hose, 3.5 x 3 (di = Ø 3.5 mm),
approx. 50 mm long
- ⑨ fuel hose, 5 x 3 (di = Ø 2 mm),
approx. 50 mm long
- ⑩ fuel pipe, 4 x 1.25 (di = Ø 1.5 mm)
- ⑪ connection fitting, da = Ø 4 mm

Possible pipe lengths

Intake side
a = max. 2 m

Pressure side
b = max. 4 m for petrol
b = max. 6 m for diesel

Please note!

Items ② ⑦ ⑪ are included in the "tank connection" kit (order no. 22 1000 20 07 00).



Caution!

Safety instructions for the fuel supply!

- The fuel must not be conveyed by gravity or overpressure in the fuel tank.
- Withdrawal of fuel after the vehicle's fuel pump is not allowed.
- When the pressure in the fuel pipe is more than 0.2 bar to max. 2 bar, use a pressure reducer (order no. 22 1000 20 09 00) or separate tank connection.
- When the pressure in the fuel pipe is more than 2 bar or there is a non-return valve in the return pipe (in the tank), a separate tank connection must be used.
- When using a T-piece in a plastic pipe, always use support sleeves in the plastic. Connect the T-piece and the plastic pipe with corresponding fuel hoses and secure with hose clips.

3 Installation

Fuel supply

Installation position of the dosing pump

Always mount the dosing pump with the pressure side rising upwards. Every installation position over 15° is allowed, although an installation position between 15° and 35° is preferable.

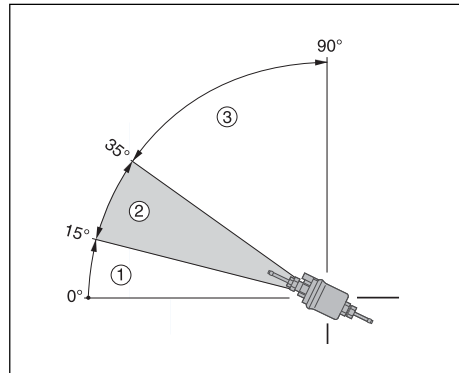

- ① installation position between 0° and 15° is not allowed.
- ② preferred installation position in range 15° to 35°
- ③ installation position in range 35° to 90° is allowed

Possible suction and pressure height of the dosing pump

Pressure height from vehicle tank to dosing pump:
a = max. 3000 mm

Intake height in pressure-less vehicle tank:
b = max. 500 mm for petrol
b = max. 1000 mm for diesel

Intake height in vehicle tanks with withdrawal by negative pressure (valve with 0.03 bar in tank cap):
b = max. 150 mm for petrol
b = max. 400 mm for diesel

Pressure height of the dosing pump to the heater:
c = max. 2000 mm

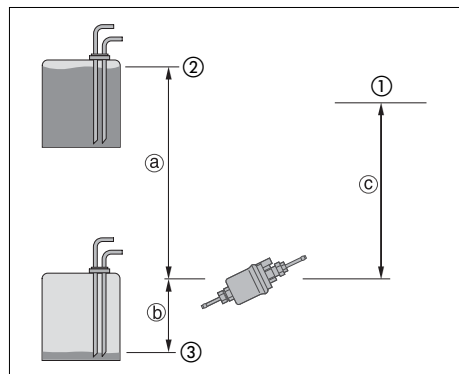

- ① connection to heater
- ② max. fuel level
- ③ min. fuel level

Please note!

Check tank venting.



Caution!

Safety instructions for installing the dosing pump

- Always mount the dosing pipe with the pressure side rising upwards – minimum incline 15°.
- Protect the dosing pump and filter from intolerable heat, do not mount near to the silencers and exhaust pipes.

3 Installation

Fuel supply

Fuel quality for petrol heaters

The heater can run on commercially available fuel as per DIN EN 228, as used in the vehicle tank.

Fuel quality for diesel heaters

In special cases (above 0°C), the heater can also run on fuel oil EL or paraffin.

Fuel for low temperatures

Refineries and fuel service stations automatically adjust the fuel to normal winter temperatures (winter diesel). This means that difficulties are only to be expected for extreme drops in temperature, as also apply to the vehicle engine. Please also refer to the vehicle manual.

If the heater is run from a separate tank, please comply with the following rules:
For temperatures above 0°C, any kind of diesel fuel as per DIN EN 590 can be used.

If no special diesel fuel is available for low temperatures, then paraffin or petrol should be mixed with the fuel according to the following table:

Temperature	Winterdiesel	Addition
0 °C bis -25 °C	100 %	---
-25 °C bis -40 °C	50 %*	50 % paraffin or petrol

* or 100% special cold diesel fuel (Arctic diesel)

Please note!

- Mixtures with used oil are not allowed!
- After refuelling with winter or cold diesel or the listed blends, the fuel pipes and the dosing pump must be filled with the new fuel by letting the heater run for 15 mins.!

Operation with biodiesel (PME)

The heater is **not** certified for operation with biodiesel.



4 Operation and function

Operating instructions

If the vehicle engine is not providing enough heat in the warming-up phase, in city traffic or in traffic congestion, the heater switches on automatically and supports the vehicle's own heating system.

Important instructions for operation

Safety checks before the start

After a longer interval in operations (after the summer months) the fuse must be put in position and/or the heater connected up to the battery. Check that all parts fit firmly (tighten screws where necessary). Check the fuel system visually for any leaks.

Heating at high altitudes

When using the heater at high altitudes, please note:

- Heating at altitudes up to 1500 m:
 - Unlimited heating possible
- Heating at altitudes over 1500 mm:
 - Heating is possible for short periods at this altitude (e.g. driving over a mountain pass or taking a break in a journey)
 - Heating is not possible for longer periods at this altitude (e.g. winter camping).

Initial commissioning

- After installation of the heater, the coolant circuit and the whole fuel supply system must be vented carefully. Comply with the instructions issued by the vehicle manufacturer.
- Open the coolant circuit before the trial run (set the temperature control to "open").
- During the trial run of the heater, check all water and fuel connections for leaks and firm fitting.
- If the heater shows a fault during operation, find and eliminate the cause of the fault using a diagnosis unit.

Description of functions

Switching on (additional heating mode)

After a certain program sequence, the heater starts the combustion air fan, glow plug and fuel dosing pump. Once a stable flame has formed in the combustion chamber, the glow plug switches off again under time control.

Heating mode

Depending on heating requirements, the heater is adjusted in the following stages:

LARGE – SMALL – OFF (pause).

The temperature limits are permanently programmed in the electronic controller.

If the heating requirements in the "SMALL" stage are so small that the cooling water temperature reaches 85°C, the heater goes into the pause mode.

The heater continues to run on for approx. 130 seconds, then it switches off (pause mode).

The control lamp lights up and the water pump continues to run, even in the pause mode.

4 Operation and function

Control and safety devices

- If the heater does not ignite within 90 seconds after starting the fuel pump, the start is repeated. If the heater still does not ignite after another 90 seconds, the heater is switched off. After an unacceptable number of failed start attempts, the controller is locked.*
- If the flame goes off by itself during operation, the heater is restarted. If the heater does not ignite within 90 seconds after the fuel pump has started again, the heater is switched off. The fault shutdown can be cancelled by switching off and on again briefly (ignition ON / OFF).
- In the case of overheating (e.g. lack of water, poorly vented coolant circuit), the overheating sensor triggers, the fuel supply is interrupted and the heater switched off. Once the cause of overheating has been eliminated, the heater can be started by switching off and on again (ignition ON / OFF), on condition that the heater has cooled down again sufficiently, cooling water temperature <70°C. After the heater has been switched off for overheating an unacceptable number of times, the controller is locked.*
- The heater is switched off if the upper or lower voltage limit is reached.
- The heater does not start up when the glow plug is defect or when the electric lead to the dosing pump is interrupted.
- The speed of the fan motor is monitored continuously. If the fan motor does not start up, if it is blocked or if the speed falls below 40% of the nominal speed, the heater is switched off after 60 sec.

* The controller can be enabled again and the faults read off:

- by connecting up a diagnosis unit
- the customer service program KD2000.

Or operation and fault list, please refer to the enclosed operating instructions or the troubleshooting and repair instructions for the heater.

Please note!

Do not switch the heater off and on again more than twice.

Emergency shutdown – EMERGENCY OFF

If an emergency shutdown – EMERGENCY OFF – is necessary during operation, proceed as follows:

- Switch heater off (ignition OFF).
- Pull the fuse out or
- Disconnect the heater from the battery.

5 Electrical system

Heater wiring



Caution!

Safety instructions for wiring the heater!

The heater is to be connected up electrically according to the EMC directives. EMC can be affected if the heater is not connected up correctly. For this reason, comply with the following instructions:

- Ensure that the insulation of electrical cables is not damaged. Avoid: chafing, kinking, jamming or exposure to heat.
- In waterproof connectors, seal any connector chambers not in use with filler plugs to ensure they are dirt-proof and water-proof.
- Electrical connections and ground connections must be free of corrosion and firmly connected.
- Lubricate connections and ground connections outside the heater interior with contact grease.

Please note!

Comply with the following when wiring the heater and the control element:

- Electrical leads, switchgear and controllers must be arranged in the vehicle so that they can function perfectly under normal operating conditions (e.g. heat exposure, moisture etc.).
- The following cable cross sections are to be used between the battery and heater. This ensures that the max. tolerable voltage loss in the cables does not exceed 0.5 V for 12 V or 1 V for 24 V rated voltage.

Cable cross sections for a cable length of
– up to 5 m (plus cable + minus cable) =
cable cross section 4 mm²
– from 5 to 8 m (plus cable + minus cable) =
cable cross section 6 mm²
- If the plus cable is to be connected to the fuse box (e.g. terminal 30), the vehicle cable from the battery to the fuse box must be included in rating the overall cable length and possibly re-dimensioned if necessary.
- Insulate unused cable ends.

5 Electrical system

Circuit diagram

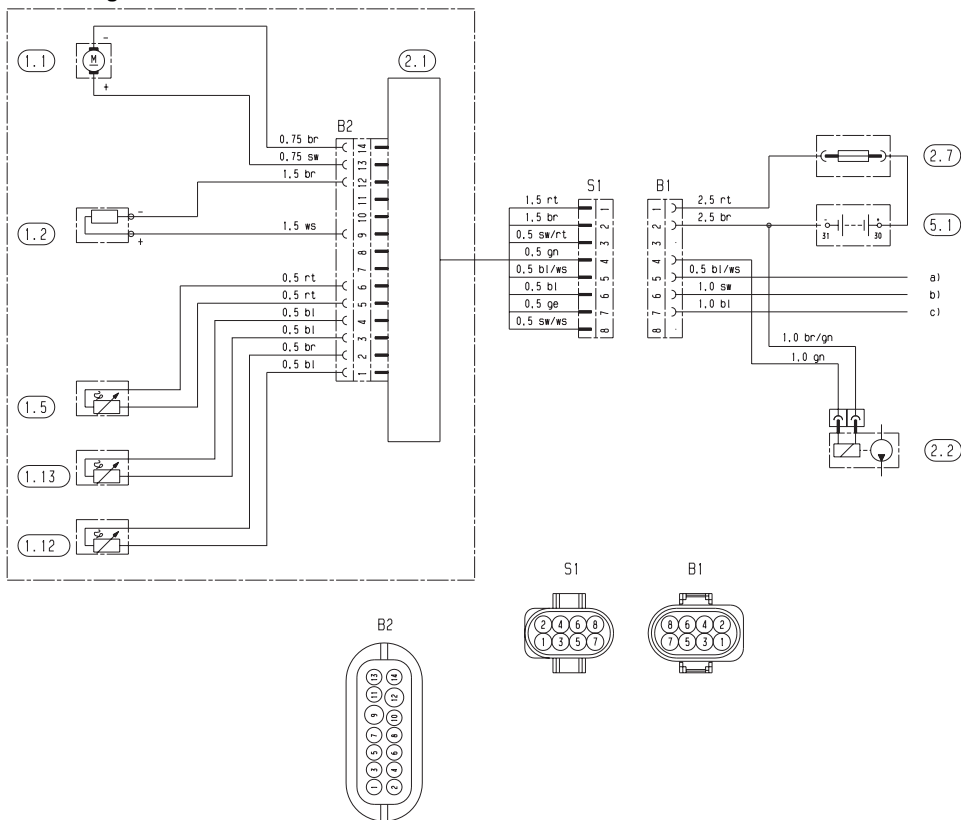

Parts list

- 1.1 Burner engine
- 1.2 Glow plug
- 1.5 Overheating sensor
- 1.12 Flame sensor
- 1.13 Temperature sensor

- 2.1 Controller
- 2.2 Dosing pump
- 2.7 Main fuse 25 A

- 5.1 Battery

- a) Diagnosis
- b) +15
Option: a temperature switch and / or an ON / OFF switch can be fitted in this line
- c) D+ dynamo

Connectors and bush housings are shown from the cable inlet side.

Cable colours

- rt = red
- bl = blue
- ws = white
- sw = black
- gn = green
- gr = grey
- ge = yellow
- vi = violet
- br = brown
- li = purple



6 Troubleshooting / Maintenance / Service

When faults occur, please check the following:

- If the heater does not start after being switched on:
 - Switch the heater off and on again.
- If the heater still does not start, check whether:
 - there is fuel in the tank?
 - the fuses are OK?
 - the electrical cables, connections etc. are OK?
 - anything is clogging the combustion air supply or exhaust system?

Maintenance instructions

- Before the heating period starts, the heater should undergo a trial run.
If persistent extreme smoke develops, unusual burning noises or a clear fuel smell can be perceived or if electric/electronic parts heat up, the heater must be switched off and put out of service by removing the fuse.
In this case, the heater should not be started up again until it has been checked by qualified staff who have been trained on Eberspächer heaters.
- Check the openings of the combustion air supply and exhaust system after longer standstill periods, clean if necessary!

Service

If you have any technical queries or problems with your pre-heater, dial the following service phone number:

Hotline
Phone. 0800 / 12 34 300

Fax hotline
Fax 01805 / 26 26 24

7 Environment

Certification

The high quality of Eberspächer's products is the key to our success.

To guarantee this quality, we have organised all work processes in the company along the lines of quality management (QM).

Even so, we still pursue a large number of activities for continuous improvement of product quality in order to keep pace with the similarly constantly growing requirements made by our customers.

All the steps necessary for quality assurance are stipulated in international standards.

This quality is to be considered in a total sense.

It affects products, procedures and customer/supplier relationships.

Officially approved public experts assess the system and the corresponding certification company awards a certificate.

Eberspächer has already qualified for the following standards:

**Quality management as per
DIN EN ISO 9001:2000 and ISO/TS 16949:1999**

**Environment management system as per
DIN EN ISO 14001:1996**

Disposal

Disposal of materials

Old devices, defect components and packaging material can all be separated and sorted into pure-grade fractions so that all parts can be disposed of as required in an environment-friendly manner or recycled where applicable.

Electric motors, controllers and sensors (e.g. temperature sensors) are deemed to be "electronic scrap".

Dismantling the heater

The heater is dismantled according to the repair stages in the current troubleshooting/repair instructions.

Packaging

The packaging of the heater can be kept in case it has to be sent back.

EU Declaration of Conformity

With regard to the following products

heater type *HYDRONIC*

we herewith confirm that it conforms with the prime safety requirements stipulated in the directives of the EU Council for harmonisation of the legal regulations of the member states with regard to electromagnetic compatibility (89 / 336 / EEC).

This declaration applies to all heaters produced according to the production drawings *HYDRONIC* which are an integral part of this declaration.

The following standards/directives have been used to assess the product with regard to electromagnetic compatibility:

- EN 50081 – 1 Basic form interference emission
- EN 50082 – 1 Basic form interference resistance
- 2 / 245 / EEC – Modification status 95 / 54 / EU interference suppression in motor vehicles



8 Guarantee conditions

Guarantee

We guarantee the assured characteristics and freedom from faults in conformity with the current state of the art. Changes in design which we execute in fulfilment of an order are not an entitlement for complaint.

The guarantee covers a period of 24 months; for retrofitting the period commences with the date when the heater was installed; for serial installation the period commences with the date of acceptance of the vehicle with the heater. This presupposes that the completed guarantee card is immediately returned after the heater has been installed.

We are entitled to choose within the guarantee whether an objected product is to be repaired or replaced. Replaced parts become our property and must be forwarded to us, together with the guarantee application, by way of the servicing workshop. With heaters the objected part must be immediately brought in the installed state to the servicing workshop so that the fault can be remedied and a written guarantee claim can be submitted. If visiting the servicing workshop involves unjustifiable expenses (e.g. with building machinery), then the nearest servicing workshop must be informed, and the objected part must be kept in readiness for assessment.

Furthermore, we bear the dismantling and installing costs for parts that are built into vehicles or stationary equipment. However, this presupposes that the work is completed by us or a workshop authorised by us. In the event of unusual dismantling and installing conditions, e.g. due to the peculiarities of the given vehicle, we will only bear the expenses to a commensurate extent. If the repair work is completed at the ordering party, then the ordering party must bear the cost of travel time and travel expenses. There is no right to claim rescission or a reduction, except if we are unable to remedy the fault. The guarantee obligation becomes null and void if the delivered object is changed by a third party or by incorporating parts of alien origin, except if the fault is not in a causal connection with the change. It also becomes null and void if mounting and operating rules have not been observed. Natural wear and damage resulting from improper treatment or overloading are exempted from the guarantee. Moreover, we cannot be held liable for the changed state or manner of operation of our products due to improper storage as well as climatic or other influences. The guarantee does not cover faults resulting from constructional peculiarities or the selection of unsuitable materials or inappropriate installation in a vehicle which the ordering party has stipulated contrary to our previous information. The guarantee obligation is not extended or renewed as a result of the repair or replacement.

Liability

In so far as there are no alternative provisions in these conditions, claims for compensation, particularly as a result of a positive contract violation and violation of mutual confidence in the preparation of a contract, are excluded to the legally permissible extent. If action based on law that is not modifiable is taken against the ordering party on account of fault liability vis-à-vis a third party, then we will support the ordering party to the same extent as the ordering party would be directly liable.

The principles of § 254 BGB (German Civil Code) are applicable to compensation for damage between the ordering party and us. This also applies in the event that we directly assert a claim.

Place of jurisdiction

The place of jurisdiction is the competent court for Esslingen or, according to our choice, the competent court for the domicile of the workshop that executed the order, provided that:

- The customer is a merchant who has been entered as such in the Commercial Register;
- The customer does not have a general inland place of jurisdiction, or
- after the contract was concluded, the customer moves his domicile or customary whereabouts away abroad, or if the customer's domicile or customary whereabouts is unknown when a suit is filed.

We are also entitled to file a suit with the court that is competent for the seat or branch of the ordering party.

9 Lists

List of key words A – Z

Keyword	Page
A	
Accident prevention	7
Arrangement of the heater	5
B	
Biodiesel (PME)	24
Bubble formation	24
C	
Cable colours	28
Certification	30
Circuit diagram	28
Combustion air system	19
Concept of this manual	3
Connection cooling water circuit	16, 17
Control and safety devices	26
D	
Description of functions	25
Disposal	30
Dosing pump	23
E	
Electrical system	27 – 28
Electronic components	33, 34
Emergency shutdown	26
Environment	30
EU Declaration	30
EU Type Permit	5
Exhaust system	18
F	
Fastening	16
Fuel supply	20 – 24
Fuel quality	24
G	
Guarantee	31
H	
Heater wiring	27
Heating operation	31
Heating mode	25
I	
Initial commissioning	25
Installation	13 – 24
Installation example	13
Installation location	13
Introduction	2 – 7

Keyword	Page
L	
Liability	31
List of abbreviations	33
List of key words	32, 33
M	
Main dimensions	12
Maintenance instructions	29
Mounting and fastening	14
Mounting the exhaust system	18
N	
Nameplate	15
O	
Operating instructions	25
Operation and function	25 – 26
Operating status display	5
P	
Parts list	28
Picture symbols	4
Place of jurisdiction	31
Possible pipe lengths	21, 22
Power consumption	10, 11
Presentations	4
Product information	8 – 12
Proper use	4
Protection	10, 11
Purpose	4
R	
Rated voltage	12, 13
Regulation	5, 6
S	
Safety checks	25
Safety instructions	6, 7
Scope of supply	8, 9
Service	29
Special text structure	4
Statutory regulations	5, 6
Storage temperature	10, 11
Switching on	25



9 Lists

List of key words A – Z

Keyword	Page
T	
Technical data	10, 11
Text structure	4
T-piece	21
Troubleshooting	29
V	
Voltage	10, 11
Voltage limit	10, 11
W	
When faults occur	29

List of abbreviations

EU Type Permit

Permit awarded by the Federal Vehicle Office for the production of a heater for installation in motorised vehicles.

EMC directive

Electromagnetic compatibility.

JE partner

J. Eberspächer partner.

PME

Biodiesel as per DIN V 51606.





